

CL Challenger Lifts



Model#: CL7P

2-Post Drive-On Pad Lift
Asymmetric Fixed Pad
7,000 lb. capacity

CL7P **Fixed Pad** **2-Post**

Asymmetric Fixed Pad Drive-On style two post features fixed pad ramps mounted on our CL10series two post automotive lift. Comes standard with (4) two position adapter blocks.

Perfect for quick vehicle spotting and express service such as quick lubes, tire rotations and balancing, brake work and other general service when productivity is essential. CL7P expedites brake and tire work with an optional heavy-duty Tire Hanger Kit which allows tires to be stowed at an ergonomic height for quick access.

Features & Benefits:

- Fixed drive-on style pad provides quick vehicle spotting for express bays
- Optional Tire Hanger Kit allows tires to be stowed at an ergonomic height for quick access. Front tires are stored on lift column mounted rod and rear tires on rear pad tire hanger rod
- Perfect for quick vehicle spotting and express service such as quick lubes, tire rotations and balancing, brake work and other general service when productivity is essential
- Grease fittings located on arm pin bushings minimize corrosion to keep arms swinging freely
- 48" elongated carriage design decreases load on bearing
- Heavy-Duty 5" diameter pulley and 5/16" cable reduces stress on equalization system and increases cable life
- Padded overhead shut off system prevents vehicle damage
- Single-point mechanical lock release system allows technician to disengage both column locks simultaneously
- Rubber door guards protect vehicles from door damage
- Pad to swing arm option
- Many accessories available - reference the Challenger Lifts 2-Post Accessories sheet for details

For more information, contact your Authorized Challenger Lifts Distributor:

CL7P	Specifications
Lifting Capacity	7,000 lb. (3175kg)
A Rise Height	70 ³ / ₄ " (1797mm)
B Column Height	11' 8" (3556mm)
C Cylinder Overall (Full Stroke)	11' 11" (3632mm)
D Width Overall	11' 6 ¹ / ₂ " (3518mm)
E Drive-Thru Clearance	88 ³ / ₁₆ " (2240mm)
F Floor to Overhead Switch	11' 2 ¹ / ₂ " (3416mm)
G Fixed Pad Height	2 ³ / ₄ " (70mm)
H Fixed Pad Width	17" (432mm)
I Fixed Pad Length	52" (1321mm)
J Width Between Fixed Pads	48 ⁵ / ₁₆ " (1227mm)
K Inside of Columns	110" (2794mm)
Motor	2HP, Single Phase, 60Hz
Voltage	208 - 230v
Speed of Rise	48 seconds
Ceiling Height Required	12' (3658mm)

Fixed Pad Superstructure specifications are based on CL10 lift installed at 110" width.

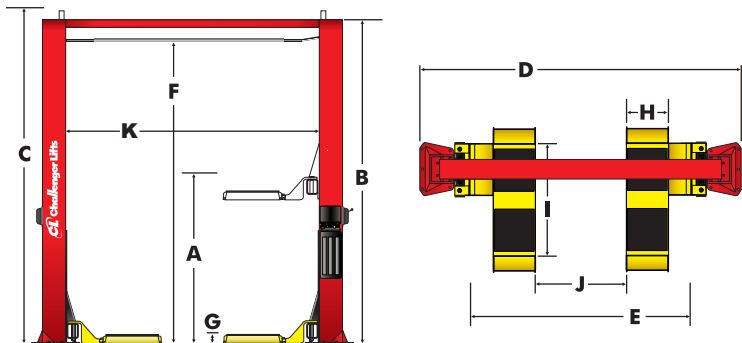

CL7P Fixed Pad Drive-On Lifts Shown with Optional Accessories



(4) two position adapter blocks



AAIA
Automotive Aftermarket
Industry Association

CHALLENGER LIFTS, INC.
200 Cabel Street
Louisville, Kentucky 40206

Phone Toll-Free: 800-648-5438
502-625-0700
Fax: 502-625-0711
www.challengeriifts.com
E-mail: sales@challengeriifts.com

Challenger Lifts, Inc. reserves the right to make changes to specifications without notice and without making changes retroactive. Unloading, installation and oil not included.