

# CL Challenger Lifts



**Model#: CL4P9X**  
Home/Commercial Storage 4-Post Lift  
9,000 lb. lifting capacity  
Storage Application



**Model#: CL1750A**  
Motorcycle, ATV and UTV Lift  
1,750 lb. capacity  
(shown with optional Deluxe Wheel Clamp)



## Home Enthusiast Lifts

**Do It Yourself & Light-Duty  
Commercial Service**

Challenger's CL4P9H, CL4P9X and CL4P9W 9,000 lb. capacity 4-post lift was designed with versatility in mind. From home enthusiast and commercial storage applications to light duty general service applications, these lifts compliment your service needs and are loaded with real benefits. They are essential for the "do it yourself" home garage, providing the best of both worlds - store a vehicle up top and below with up to 80" of clearance when the lift is fully raised, or use this lift to service your vehicles.

CL1000A and CL1750A Motorcycle Lift allows you to lift any bike, ATV, or UTV up to 1,750 lbs. CL1750A's air operated double foot pedal makes this lift safe and easy to operate. Choose from many optional accessories to personalize this lift to fit your service needs.

## Storage/Light Duty Service Lift



Challenger's 9,000 lb. capacity CL4P9H, CL4P9X and CL4P9W are perfect for home garage and commercial storage and light duty general service applications. Bolt it down or leave it free standing so you can relocate it anywhere. With extended length and width models, these service and home storage units provide unlimited options for the DIY car enthusiast.

With optional rolling jacks, ramp upgrades, oil drain pan, etc., you'll be able to accommodate just about anything that comes in your garage and afford room to grow with its reasonable cost. Available in black only.

### Features & Benefits:

- Heavy-duty commercial grade design with rigid formed columns and runways for superior strength and dependability, yet light enough to move around the garage (with optional caster set)
- 115v standard plug-in power unit with optional 220v version available
- Versatile design allows it to be either Free-Standing or Bolt-to-Floor
- Built-in runway rail system accommodates optional rolling jacks, jack trays, drip trays, and storage platforms
- Single hydraulic cylinder protected underneath runway
- Large molecular composite slider blocks for minimal wear and maximum dependability

### Multiple Power Unit Locations

The power unit can be placed either on the front column of the drivers side or the back column of the passenger side of the lift. This provides convenient power control accessibility and versatility for any garage layout.



### Service Application

Professional grade quality with 80" high rise and multiple lock positions is perfect for light duty service up to 9,000 lb. capacity. Optional rolling jacks and jack trays provide quick tire and brake work access.

### Storage Application

It's the best of both worlds. Service your vehicles or store them up top. With 80" rise height, most full size vehicles are easily parked underneath for everyday use. Optional drip tray set completes the storage application, keeping any fluids from contacting the vehicle underneath.

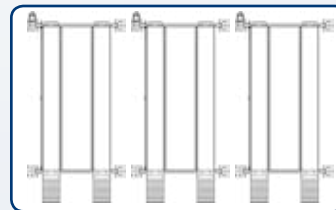

Multiple unit storage lifts available with full CAD layout support

### Optional-Accessories

**RJ4.5:**  
4,500 lb.  
Capacity  
Rolling Jack



**CL4P9DT:** Drip Tray Set (set of 3)



**CL4P9SR:**

Bolt-on steel and hinged Approach Ramps with wheel stop



**CL4P9JT:** 4,500 lb. capacity Jack Tray



**CL4P9ER:** 50" Optional Extended Aluminum Ramps



**CL4P9CS:** Caster Set (set of 4)

## Motorcycle, ATV and UTV Lift

Challenger's 1,000 lb. and 1,750 lb. capacity motorcycle/ATV lifts are perfect for anyone who owns and works on motorcycles or ATVs. CL1750A's Dual foot pedal air controls makes this lift safe and easy for anyone to operate.

Optional wheel clamps, center jacks, and extensions provides the complete motorsports service application. Available in black only.



www.challengelifts.com

### Drop Panels - CL1750A Models Only

Built-in front and rear platform drop panels provide quick access to reach and remove front and rear tires. Optional Universal Jack compliments this application.

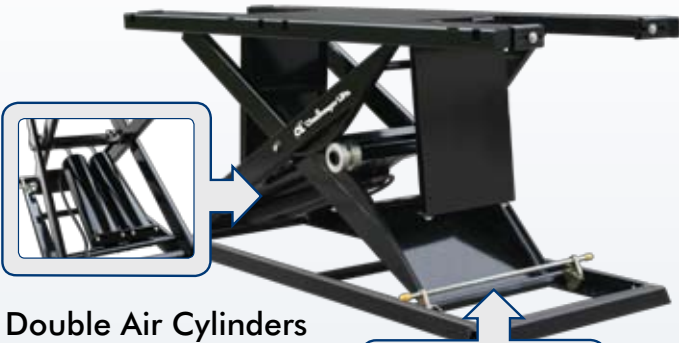

### Double Air Cylinders

Provide efficient and stable lifting power to easily and safely lift up to 1,750 lbs.



### Automatic Safety Locks

Allows the lift to be locked at multiple heights so you can work comfortably.

### Features & Benefits:

- Heavy-duty scissor style lift with formed platforms
- Air operated dual foot pedal for easy operation (CL1750A Models Only)
- Integrated base provides stable, smooth operation
- Solid approach ramps with rear drop feature for quick access to rear wheel.
- Multiple safety locking positions

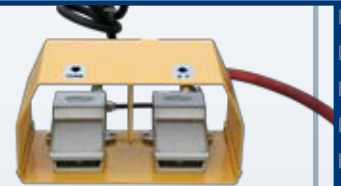

### Air Operated Double Foot Pedal

Makes it safe and easy to raise and lower the lift. (CL1750A Models Only)

### Optional-Accessories

#### CLML01UJ: Universal Jack

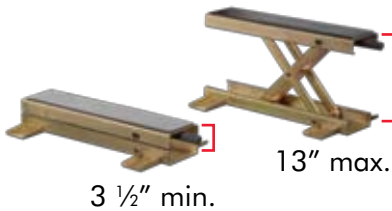

3 1/2" min.

13" max.

#### CLML01WC: Deluxe Wheel Clamp

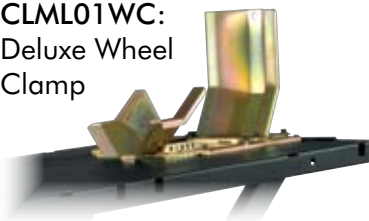

#### CLML01CJ: Hand Operated center jack

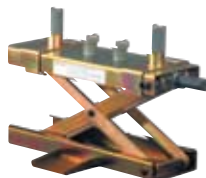

CLML02SP: Side Panel extends platform width to 56" for ATV/UTV application

CLML01SP: Side Panel extends platform width to 48" for ATV/UTV application



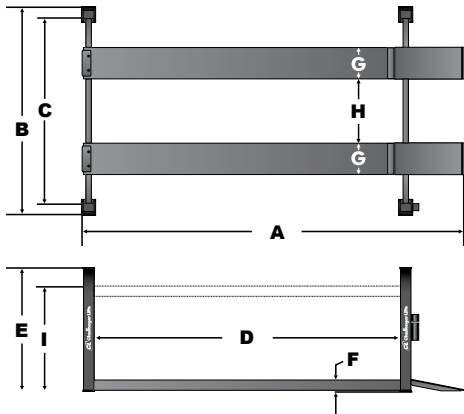

Model	CL4P9S	CL4P9X	CL4P9W
Lifting Capacity	9,000 lbs. (4082 kg)		
<b>A</b> Length Overall	209 1/2" (5321mm)	233 1/2" (5931mm)	
<b>B</b> Width Overall	112 1/4" (2851mm)		127 1/4" (3232mm)
<b>C</b> Inside Columns	95" (2413mm)		110" (2794mm)
<b>D</b> Between Columns	160 1/2" (4077mm)	184 3/4" (4993mm)	
<b>E</b> Height of Columns	84 1/2" (2146mm)	96 1/2" (2451mm)	
<b>F</b> Height of Runways	6" (152mm)		
<b>G</b> Width of Runways	20" (508mm)		
<b>H</b> Width Between Runways	37 1/2" (983mm)		
<b>I</b> Rise Height	73 1/4" (1861mm)	85 1/2" (2172mm)	
Motor	1HP		
Voltage (1 Phase Std) <sup>1</sup>	115v		
Speed of Rise <sup>1</sup>	120 Seconds		
Min. Recommended Bay Size	11' x 22' (3353mm x 6707mm)	11' x 22' (3353mm x 6707mm)	14' x 22' (4267mm x 6707mm)

<sup>1</sup> Optional 220v power for 60 second rise time available. Must be specified at time of order. Available in Black only.

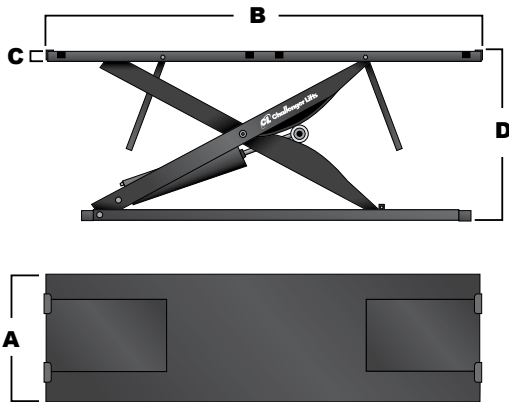

Model	CL1000A	CL1750A
Lifting Capacity	1,000 lbs (450kg)	1,750 lbs (787kg)
<b>A</b> Overall Width	24" (610mm)	29 1/2" (750mm)
<b>B</b> Overall Length	84" (2130mm)	86 1/2" (2200mm)
<b>C</b> Platform Thickness	1/16" (2.5mm)	1/125" (3.25mm)
<b>D</b> Maximum Height	35" (900mm)	40" (1016mm)
Minimum Height	7 1/4" (185mm)	8" (204mm)
Weight	350 Lbs (160kg)	496 lbs (223kg)
Maximum Air Pressure	100 PSI	100 PSI
Lifting Time	15-25 Seconds	10-15 Seconds
Lowering Time	20-30 Seconds	15 Seconds

Available in Black only.



The Automotive Lift Institute (ALI) certifies that the CL4P9H, CL4P9X and CL4P9W described herein comply with the applicable provisions of the American National Standards ANSI/ALI ALCVT 2006 and are Third Party Validated by the ETL Testing Laboratory.

**CHALLENGER LIFTS, INC.**  
200 Cabel Street  
Louisville, Kentucky 40206

Phone Toll-Free: 800-648-5438  
502-625-0700  
Fax: 502-625-0711

E-mail: [sales@challengerlifts.com](mailto:sales@challengerlifts.com)

Challenger Lifts, Inc. reserves the right to make changes to specifications without notice and without making changes retroactive. Unloading, installation and oil not included.