

# **CL** Challenger Lifts

## **Installation, Operation, & Maintenance Manual** ***Versymmetric™* Two Post** **Surface Mounted Lift** with **DUAL PENDANT CONTROL**

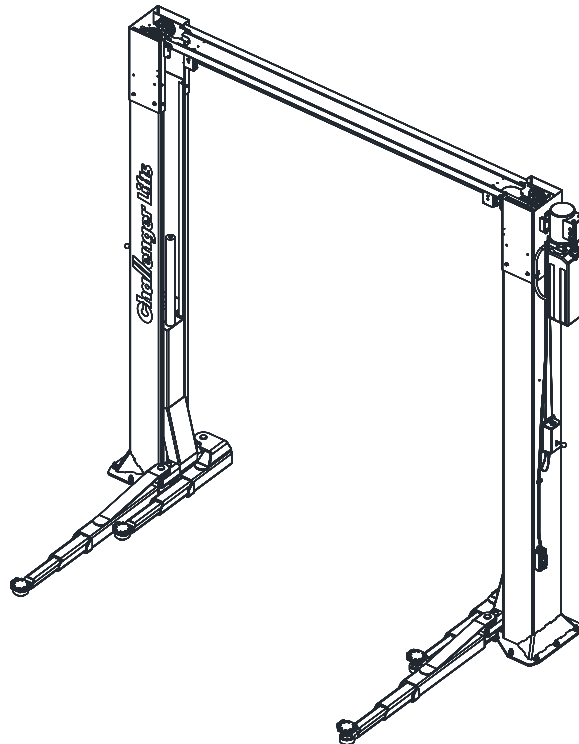

**MODELS: CL10V3-DPC**  
**CL10V3-DPC-QC (QUICK CYCLE)**

10,000 LBS. CAPACITY  
2500 LBS. PER ARM

2311 South Park Rd Louisville, Kentucky 40219

Email: [sales@challengerlifts.com](mailto:sales@challengerlifts.com) Web site: [www.challengerlifts.com](http://www.challengerlifts.com)

**Office 800-648-5438 / 502-625-0700 Fax 502-587-1933**

**IMPORTANT: READ THIS MANUAL COMPLETELY BEFORE  
INSTALLING or OPERATING LIFT**

## GENERAL SPECIFICATIONS

See Figure 1	CL10	CL10-2	CL10-3
<b>A</b> Column Height	11'-2" or 11'- 8"	13'-2" or 13'- 8"	14'-2" or 14'- 8"
* Ceiling Height Required	12'	13'- 3" or 13'- 9"	14'- 3" or 14'- 9"
<b>B</b> Cylinder Height (Full Stroke)	11'- 11"		
<b>C</b> Floor to Overhead Switch	10'-8 1/2" or 11'- 2 1/2"	12'- 8 1/2" or 13'- 2 1/2"	13'- 8 1/2" or 14'- 2 1/2"
<b>D</b> Rise Height (Screw Pads Highest Position)	74 1/8"		
<b>E</b> Screw Pad Height	3 7/8" to 6 1/8"		
<b>F</b> Adjustable Overall Width	11'- 11" or 11'- 6 1/2"		
<b>G</b> Inside of Columns	110" or 114 1/2"		
Drive Thru Clearance	100" or 104 1/2"		
Arm Reach Front/Rear (Min.-Max.)	Front (20" - 42") / Rear (37-5/8" - 60")		
Drive Thru Clearance	100" or 104 1/2"		
** Lifting Capacity (Hydraulic Pressure at Cap.)	10,000 lbs. (2500 lbs. Per Arm) (2750 psi)		
*** Rise Time	Standard DPC: 38 Sec. (approximate)		
	Quick Cycle DPC: 24 Sec. (approximate)		
Motor	Standard DPC: 2HP, Single Phase, 60Hz, 208/230V		
	Quick Cycle DPC: 3HP, Single Phase, 60Hz, 208/230V		

- \* Cylinder height "D" will extend past column height "A" on standard CL10 only.
- \*\* Lift capacity ratings are based on loads equally distributed on all four arms.
- \*\*\* Lifting and lowering speeds may vary depending on the weight of the vehicle.

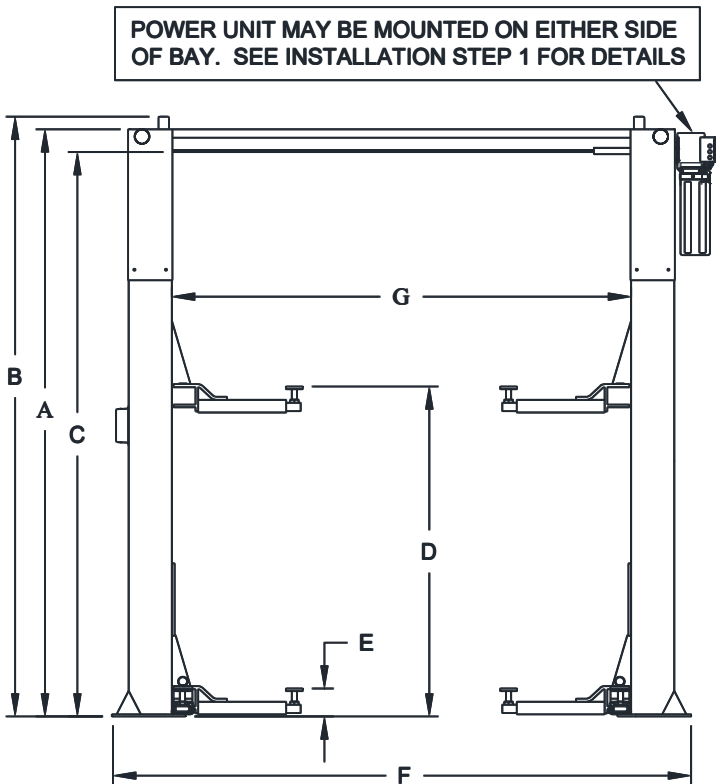

Fig 1a - General Specifications

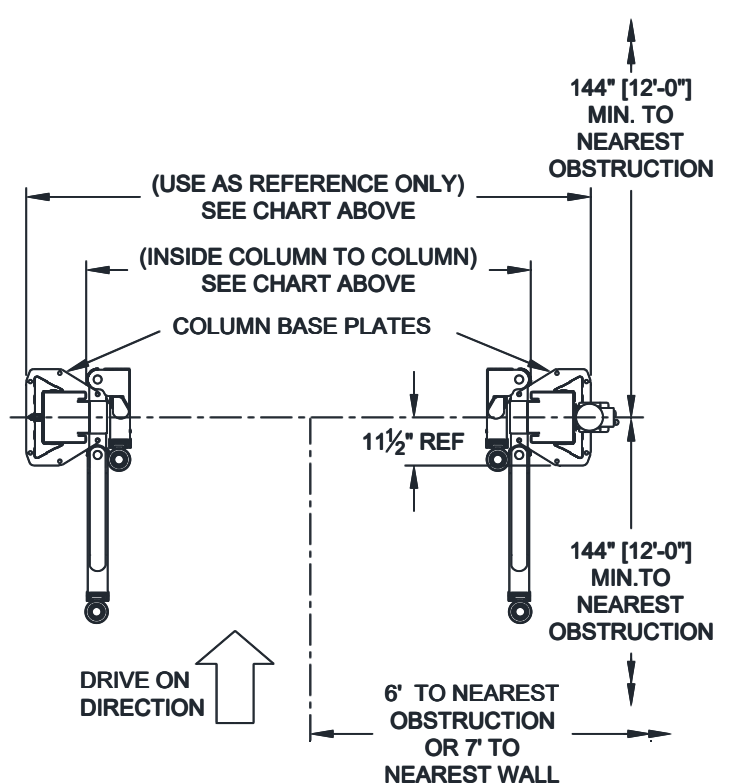

Fig 1b - Service Bay Layout

## VERTICAL CLEARANCE

Check the height of the area where the lift is to be installed. Clearance should be calculated based on the full raised height of the lift.



**WARNING** Failure by purchaser to provide adequate clearance could result in unsatisfactory lift performance, property damage, or personal injury.

## FLOORING

Be certain you have the proper concrete floor to properly handle the loaded lift. Floor should be in generally good condition with no large cracks, spalling or deterioration.

**Minimum requirements for concrete are 4 inches minimum depth, with steel reinforcement, 3500 psi, cured for 28 days per local commercial practice.** Floor should be level within 3/8 inch over the installation area. No anchors should be installed within 8 inches of any crack, edge, or expansion joint. If these conditions cannot be met, a pad may be poured to accommodate the lift.

Check with local building inspectors and/or permits office for any special instructions or approvals required for your installation.

A qualified person should be consulted to address seismic loads and other local or state requirements.



**WARNING** Failure by purchaser to provide the recommended mounting surface could result in unsatisfactory lift performance, property damage, or personal injury.

## LOCATION

This lift has been evaluated for indoor use only with an operating ambient temp. range of 5 – 40°C (41–104°F). Outdoor Installation is Prohibited.

## ELECTRICAL REQUIREMENTS

For lift installation and operation, it is necessary to have a dedicated circuit with circuit breaker or time delay fuse. Refer to wiring diagram for circuit sizing.

## SAFETY NOTICES AND DECALS

For your safety, and the safety of others, read and understand all of the safety notices and decals included here.

**READ ENTIRE MANUAL BEFORE ASSEMBLING, INSTALLING, OPERATING, OR SERVICING THIS EQUIPMENT.**

**PROPER MAINTENANCE AND INSPECTION IS NECESSARY FOR SAFE OPERATION.**

**DO NOT OPERATE A DAMAGED LIFT.**

Safety decals similar to those shown here are found on a properly installed lift. Be sure that all safety decals have been correctly installed at both points of operation. Verify that all authorized operators know the location of these decals and fully understand their meaning. Replace worn, faded, or damaged decals promptly.



**WARNING** Do not attempt to raise a vehicle on the lift until the lift has been correctly installed and adjusted as described in this manual.

<p><b>SAFETY INSTRUCTIONS</b></p> <p>Read operating and safety manuals before using lift.</p>	<p><b>SAFETY INSTRUCTIONS</b></p> <p>Proper maintenance and inspection is necessary for safe operation.</p>	<p>If attachments, or accessories, or configuration modifications are located in the load path, affect operation of the lift, affect the lift electrical listing or affect intended vehicle accommodation are used on this lift and, if they are not certified for use on this lift, then the certification of this lift shall become null and void. Contact the participant for information pertaining to certified attachments, accessories or configuration modifying components.</p> <p><b>SAFETY INSTRUCTIONS</b></p> <p>www.autolift.org ©2007 by ALI, Inc. ALI/WLS/AIO1</p>
<p><b>SAFETY INSTRUCTIONS</b></p> <p>Do not operate a damaged lift.</p>	<p>The messages and pictographs shown are generic in nature and are meant to generally represent hazards common to all automotive lifts regardless of specific style.</p> <p>Funding for the development and validation of these labels was provided by the Automotive Lift Institute, PO Box 33116 Indianatic, FL 32903</p> <p>They are protected by copyright. Set of labels may be obtained from ALI or its member companies.</p> <p>© 1992 by ALI, Inc. ALI/WLS101a</p>	

<p><b>CAUTION</b></p> <p>Lift to be used by trained operator only.</p>	<p><b>CAUTION</b></p> <p>Authorized personnel only in lift area.</p>	<p><b>WARNING</b></p> <p>Clear area if vehicle is in danger of falling.</p>	<p><b>WARNING</b></p> <p>Position vehicle with center of gravity midway between adapters.</p>
<p><b>CAUTION</b></p> <p>Use vehicle manufacturer's lift points.</p>	<p><b>CAUTION</b></p> <p>Always use safety stands when removing or installing heavy components.</p>	<p><b>WARNING</b></p> <p>Remain clear of lift when raising or lowering vehicle.</p>	<p><b>WARNING</b></p> <p>Avoid excessive rocking of vehicle while on lift.</p>
<p><b>CAUTION</b></p> <p>Use height extenders when necessary to ensure good contact.</p>	<p><b>CAUTION</b></p> <p>Auxiliary adapters may reduce load capacity.</p>	<p><b>WARNING</b></p> <p>Do not override self-closing lift controls.</p>	<p><b>WARNING</b></p> <p>Keep feet clear of lift while lowering.</p>
<p>The messages and pictographs shown are generic in nature and are meant to generally represent hazards common to all automotive lifts regardless of specific style.</p> <p>Funding for the development and validation of these labels was provided by the Automotive Lift Institute, PO Box 33116 Indianatic, FL 32903.</p> <p>They are protected by copyright. Set of labels may be obtained from ALI or its member companies.</p> <p>© 1992 by ALI, Inc. ALI/WLS101a</p>		<p>The messages and pictographs shown are generic in nature and are meant to generally represent hazards common to all automotive lifts regardless of specific style.</p> <p>Funding for the development and validation of these labels was provided by the Automotive Lift Institute, PO Box 33116 Indianatic, FL 32903.</p> <p>They are protected by copyright. Set of labels may be obtained from ALI or its member companies.</p> <p>© 1992 by ALI, Inc. ALI/WLS101a</p>	

## RECEIVING

The shipment should be thoroughly inspected as soon as it is received. The signed bill of lading is acknowledgement by the carrier of receipt in good condition of shipment covered by our invoice.

If any of the goods called for on this bill of lading are shorted or damaged, do not accept them until the carrier makes a notation on the freight bill of the shorted or damaged goods. Do this for your own protection.

NOTIFY **Challenger Lifts** AT ONCE if any hidden loss or damage is discovered after receipt.

IT IS DIFFICULT TO COLLECT FOR LOSS OR DAMAGE AFTER YOU HAVE GIVEN THE CARRIER A CLEAR RECEIPT.

File your claim with **Challenger Lifts** promptly. Support your claim with copies of the bill of lading, freight bill, and photographs, if available.

## Component Packing List

PART #	QTY/ LIFT	DESCRIPTION
A2001-DPC-57-P	1	Power Column Ass'y
A2001-57-I	1	Idler Column Ass'y
A2060	1	Overhead Beam
B2202SD	1	3-Stage Arm Pack
B2302SD	1	2-Stage Arm Pack
A2070-57-*	2	Column Extension for CL10-*
A2003-*	1	Sync Cable Pack for CL10-*
A2066	1	Overhead Shut-Off Bar Ass'y
CL10DPC-HW-A	1	Hardware Box
CL10DPC-LP-A	1	Literature Pack (in Hardware Box)
A1207-19	1	Std. DPC Power Unit – 1 Phase
AB-10397		QC DPC Power Unit – 1 Phase
A1206-15	1	Junction Box Assembly
A1206-10-PS	1	Pendant Ass'y POWER (CL10-0)
A1206-10-PX		Pendant Ass'y POWER (CL10-2 or-3)
A1206-10-IS	1	Pendant Ass'y IDLER (CL10-0)
A1206-10-IX		Pendant Ass'y IDLER (CL10-2 or-3)

**ACCEPTED OILS** – Do not use oils with detergents  
*Hydraulic fluid is not provided with the lift shipment*  
-10 wt. anti-foam, anti-rust hydraulic / biodegradable oil  
-Dexron III ATF

## Edition of Standards Referenced

Where any ANSI standard is referenced within this manual, the most recent edition approved by the American National Standards Institute, Inc. shall apply.

## INSTALLATION

### SAFETY REQUIREMENTS FOR INSTALLATION AND SERVICE

Refer to ANSI/ALI ALIS (current edition)

**IMPORTANT:** Always wear safety glasses while installing lift.

### TOOLS (MINIMUM REQUIRED)

- Tape measure, 16ft
- Chalk line
- 4ft level
- 10" adjustable wrench
- Standard open end wrenches 7/16", 1/2", (2) 9/16", (2) 11/16", 3/4", 15/16"
- 5/16" allen wrench
- Needle nose pliers
- Hammer drill with 3/4" diameter carbide tipped bits
- 2lb hammer
- Torque wrench: 150 foot pounds minimum with 1 1/8" socket
- 12 ft. Step ladder
- Anti-Seize lubricant (for arm pins and foot pad screw threads and stop rings)

### LIFT PREPARATION

- With column assemblies lying flat, remove cable and hose rolls from inside the columns and manually push carriages up to gain access to sheave at base of column.
- Remove hex bolt and cable trapping pin from sheave bracket, **Fig. 2**.

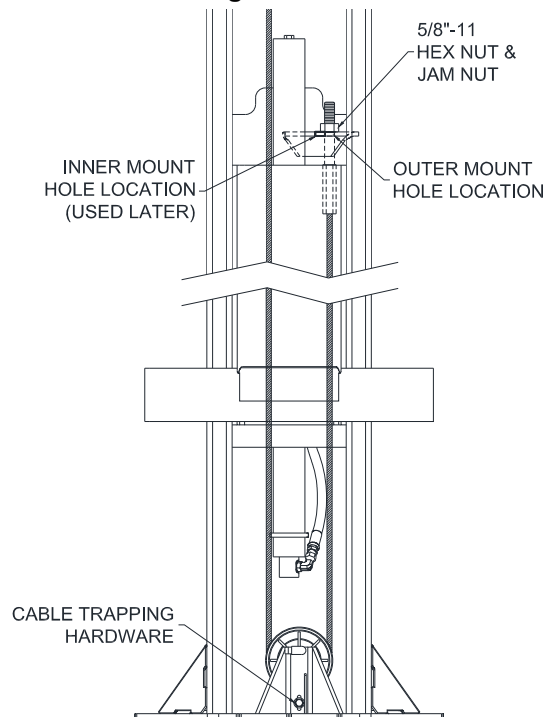

**Fig. 2 – Cable Routing LAYOUT**

- Route cables as shown in figure. Ensure cables do not wrap around hoses during routing.

- 4) Re-install cable trapping hardware and slide carriage and cylinder back down to base of lift. Ensure hydraulic hose is routed around base tabs properly to prevent rotation of the cylinder.

**IMPORTANT NOTE:**

If the lift is to be installed in the Narrow (11'-6 1/2") or Reduced Height Setting (11'-2", 13'-2", 14'-2"), see Fig. 8 NOTE before proceeding to the next step.

Ensure top of the hydraulic cylinder remains retained in the opening of the carriage top plate.



Failure to follow previous step could result in personal injury.

**LAYOUT**

- 5) Layout the service bay according to the architect's plans or owners instructions (see Fig 1b). Failure to install in this orientation can result in personal and property damage. Be certain that the proper conditions exist, see page 3.

**Note:** the only difference between the Power and Idler Column is the length of hose attached to the cylinder (long hose in Idler Column). The Power Unit may be mounted on the Power Column on either side of the bay.

- 6) Assemble column extension to column using 3/8-16 x 3/4" lg Hex flange head bolt. Repeat for opposite column and extension.

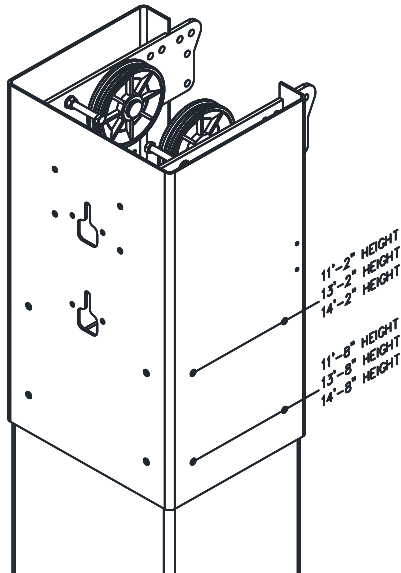

**Fig. 3 – Column Extension Assembly**

- 7) Erect both column assemblies (column with short cylinder hose on side of bay with Power Unit). Align the notches in column base, with the installation lines.

**LOCKING PAWL**

- 8) Attach 1/2" O.D. Extension Spring to hole located on bottom side of both supplied Lock Pawls, Fig. 4. Install Lock Pawl and Lock Release Clevis on

both columns using 5/8" diameter x 1 1/2" lg shoulder bolt and 1/2"-13 nylon lock nut. Attach 3/8" O.D. Extension Spring to upper hole in locking pawl and other end to hole in bracket welded to column as shown in Fig 4.

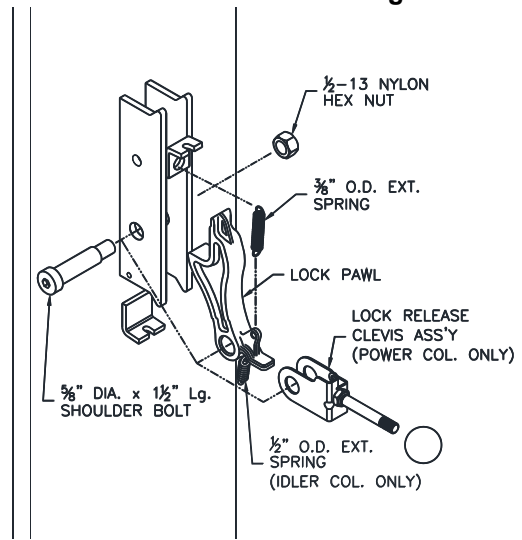

**Fig. 4 – Locking Pawl Assembly**

**ANCHORING**

Note:

- The anchor bolts must be installed at least 8" from any crack, edge, or expansion joint. Recheck the area around both base plates.
- Use a concrete hammer drill with a 3/4 inch carbide bit. Tip diameter should conform to ANSI Standard B212.15 (.775 to .787). Do not use excessively worn bits or bits which have been incorrectly sharpened. A core bit may be necessary if an obstruction is encountered. **Never substitute with shorter anchor.**

- 9) Recheck "Inside of Columns" dimension (Fig. 1).
- 10) Using the base plate as a template, drill one anchor hole. Drill through the floor if possible or to a depth of 5 inches minimum.
- 11) Clean the hole inside and out.
- 12) Assemble a washer and nut to the anchor with nut just below impact section of bolt. Drive the anchor into the hole until the nut is 3/4" above the baseplate (leaving room for shims)

**Complete steps 10 thru 12 for the five (5) exposed anchors (one at a time) around each column.**

- 13) Raise both carriages (200 lbs. ea.) high enough to drill the two inner anchor holes on each column. Measure both carriage heights to ensure they are in the same lock position.
- 14) **IMPORTANT:** Ensure that the lock pawl is engaged by attempting to manually disengage it. When properly engaged, the weight of the carriage will prevent it from moving.

- 15) Repeat steps 10 thru 12 for the two (2) anchors under each carriage.
- 16) Shim both columns to plumb using the shims provided as shown in **Fig. 5**. DO NOT shim more than 1/2" at any given point. Use a level no less than 24" in length to plumb columns.
- 17) Drive all the anchors until nut and washer contact baseplate.

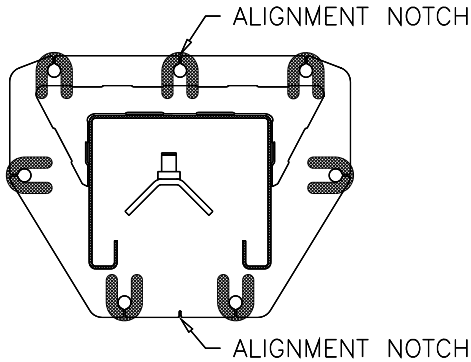
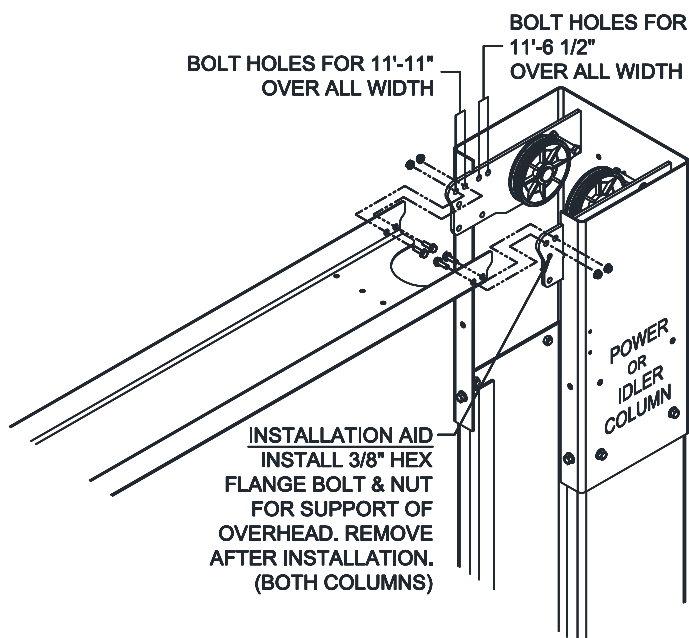

**Fig. 5 – Column Shimming**

- 18) Tighten Power Column anchors and recheck column for plumb. Re-shim if necessary. Torque to 150 foot pounds to set anchors.
- 19) Loosen Idler Column anchors 1/8" and proceed with the Overhead Beam installation.

**OVERHEAD**

- 20) Before raising overhead into position install 4 each (2 per column) hex flange bolts and nuts in middle hole of column extension (see **Fig 6 Installation Aid**) for temporary support of overhead. Lift overhead assembly up into position and install with 8 each (4 per column) 3/8-16 x 3/4" lg hex flange bolts and hex flange nuts per side as shown in **Fig 6**.

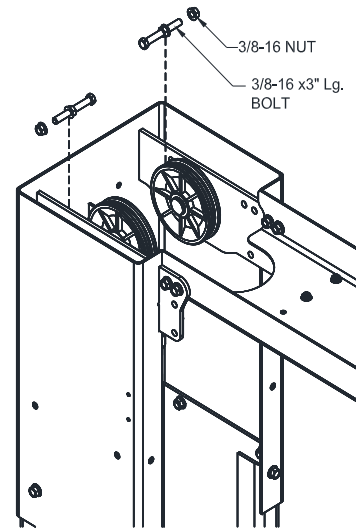

**Fig. 6 – Overhead Assembly**

- 21) Check idler column shimming. Use additional shims (see **Fig. 5**) to remove any gaps that may have been created while installing overhead beam. Tighten anchor bolts and re-check column for plumb. Torque to 150 foot pounds.

**SYNCHRONIZER CABLES**

- 22) Route free end of cables up and over the upper sheaves and back down the opposite side. At the upper sheave locations, disassemble and reassemble the cable trapping hardware after cables are routed around sheaves, **Fig. 7**.
- 23) At the top of each column extension assemble a 3/8-16 x 3" Lg bolt with (2) 3/8-16 flange nut at each sheave location, **Fig. 7**.
- 24) Repeat for opposite side.



**Fig. 7 – Column Ext. Cable Trapping**

- 25) Mount synchronizer cables to carriages as shown in **Fig. 8a**. **Note: The 4 1/2" & 12" take up tubes are to take up the sync. cable slack when the lift is in the Narrow or Reduced Height setting. These take up tubes cannot be stacked together. The 4 1/2" take up tube can be installed inside the carriage if the 12" take up tube is not being used.**
- 26) Install the hex and jam nut as shown in **Fig. 8b**.

Model CL10 with Dual Pendant Control  
Installation, Operation, and Maintenance

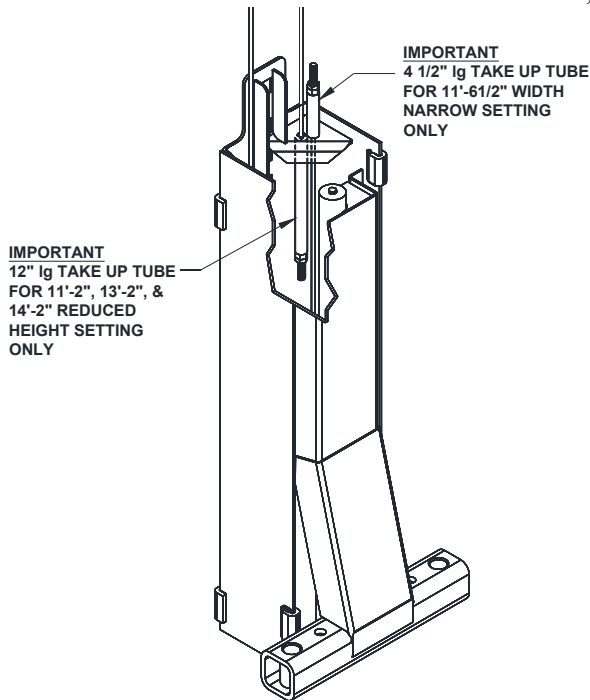

Fig. 8a – Cable Assembly

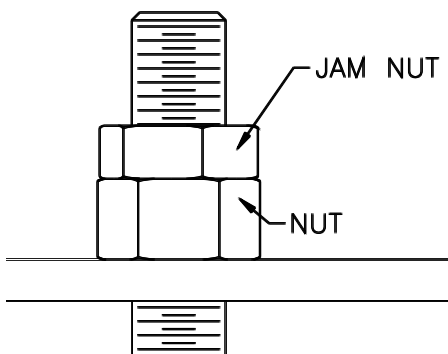

Fig. 8b – Jam Nut

**JUNCTION BOX**

27) Install Junction Box Assembly to inside of Power Column with (2) #10-32 x 1/2" lg. phillips pan head screws and flange nuts, Fig 9.

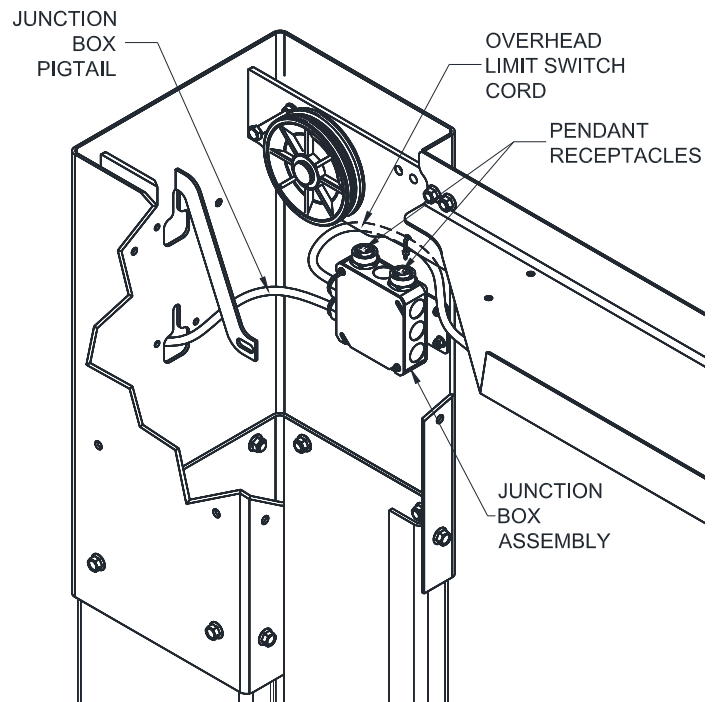

Fig. 9 – Junction Box Assembly

Route junction box pigtail through slot in back of Column Extension. This pigtail will attach to the power unit.

**OVERHEAD LIMIT SWITCH**

28) Install Overhead Limit Switch to the Overhead Beam using the rear set of holes on the Power Side of the lift. Fig. 10a.

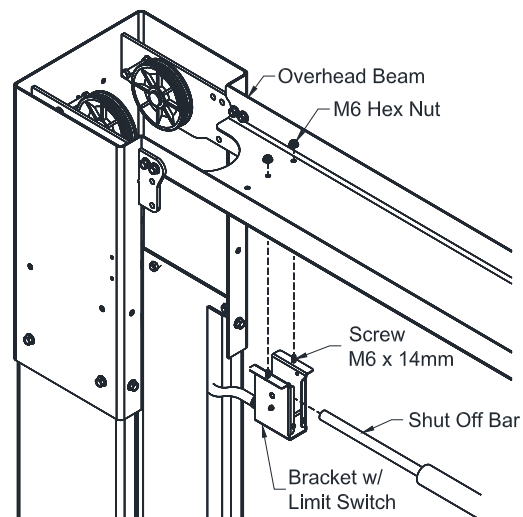
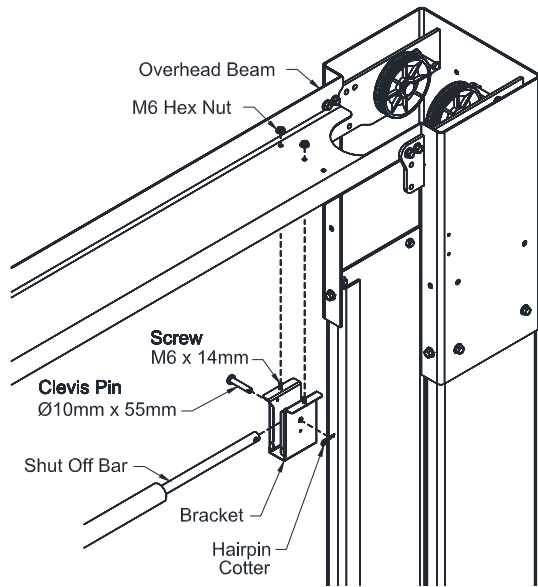

Fig. 10a – Overhead Limit Switch Power Side

29) Install the Idler Bracket to the Overhead Beam using the rear set of holes on the Idler Side of the lift. Fig. 10b. Note the orientation of the Idler Bracket. The narrow slot needs to be facing towards the Power Column. Slide the Shutoff Bar over the limit switch on the Power Side. Pin the Shutoff Bar to the Idler Side Bracket with the 10mm dia. x 55mm Lg. clevis pin & hairpin cotter.

Model CL10 with Dual Pendant Control  
Installation, Operation, and Maintenance



**Fig. 10b – Overhead Bracket Idler Side**

- 30) Connect the overhead limit switch pigtail to the receptacle in the junction box, **Fig 9**.

**PENDANT SWITCHES**

- 31) Locate the Pendant mounting hole on each column just below the lock cover on the left side. Tap hole on both columns 5/16-18NC. Hang both pendant switches using supplied 1/2" Line Clamp, 5/16-18 x 3/8 Lg. Pan Head Screw and 5/16" Split Lock Washer (**Fig. 11**). Position Line Clamp around pendant wire. Insert screw thru lock washer, free end of Cable Lanyard, and Line Clamp and secure to column.

**IMPORTANT: RISK OF EXPLOSION. THE PENDANT CONTROLS HAVE INTERNAL ARCING OR SPARKING PARTS THAT SHOULD NOT BE EXPOSED TO FLAMMABLE VAPOR. THE PENDANT CONTROLS SHOULD BE LOCATED AT LEAST 18 INCHES (460mm) ABOVE THE FLOOR.**

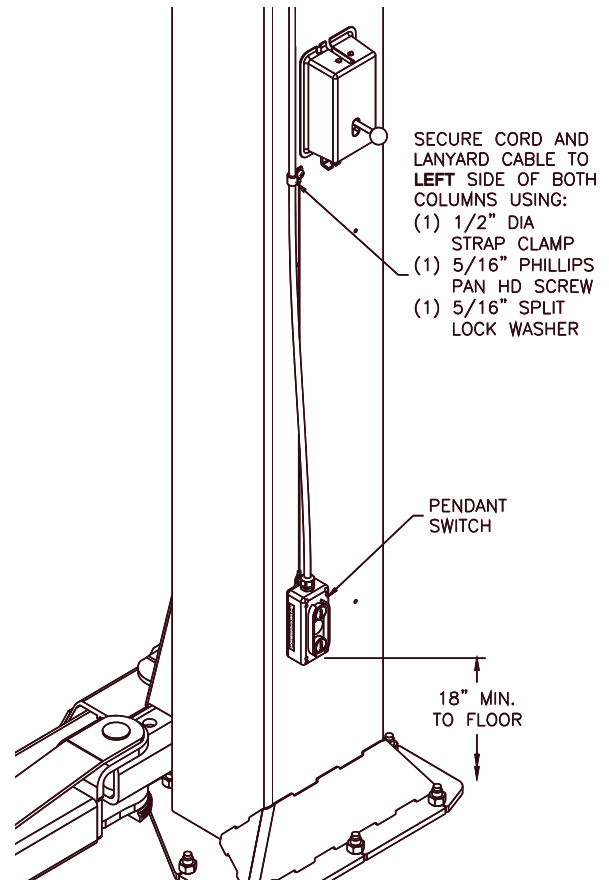

**Fig. 11 – Pendant Switch Installation**

- 32) Route both Pendant Switch cords up the column and attach with another 1/2" Line Clamp and a 3/8" bolt that connects the Column Extension to the Column. Continue the cord up the column and into the column extension slot.
- 33) Attach both Pendant end connectors to receptacles on Junction Box, **Fig 12**.

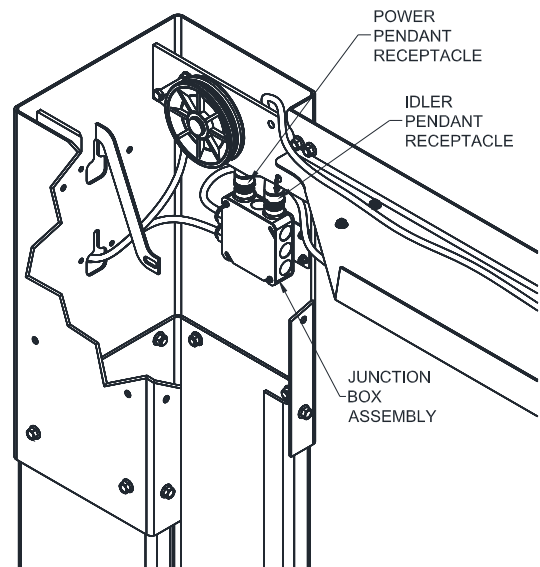

**Fig. 12 – Junction Box Assembly**



**POWER UNIT & HYDRAULIC HOSES**

**IMPORTANT – To ensure proper hose fitting seal without damage to the fitting follow this procedure for each hose connection:** Screw flared fitting on finger tight. Rotate flared fitting 1 1/2 hex flats (90 deg.). Back the flared fitting off one full turn. Again, tighten flared fitting finger tight, then rotate flared fitting 1 1/2 hex flats (90 deg.).

34) Uncoil Idler side hose and route through the Idler Side column extension as shown in **Fig. 13a**, taking care to avoid the synchronizing cables and hydraulic cylinder path. Remove slack and tighten all 3 clamps. Route hose across overhead avoiding the synchronizing cables and down through the Power Side column extension as seen in **Fig 8b**. Do Not Tighten Clamps at this time.

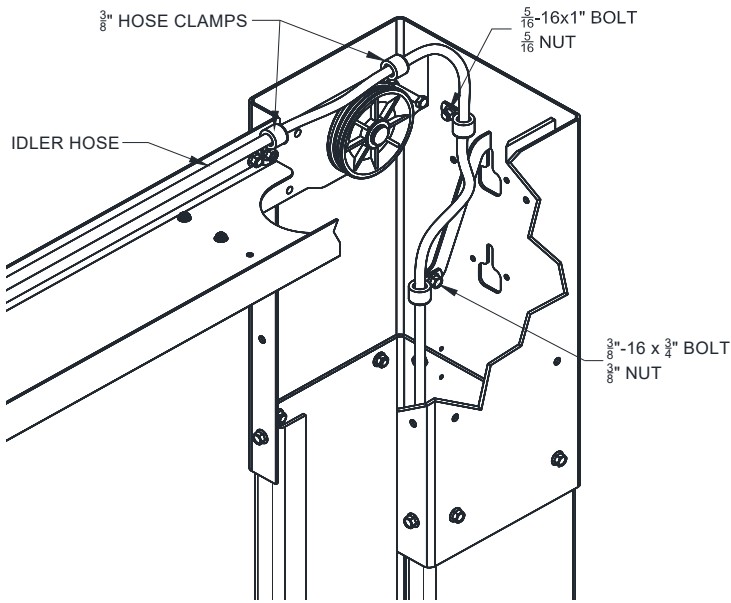

**Fig. 13a – Hose Routing, Idler Side**

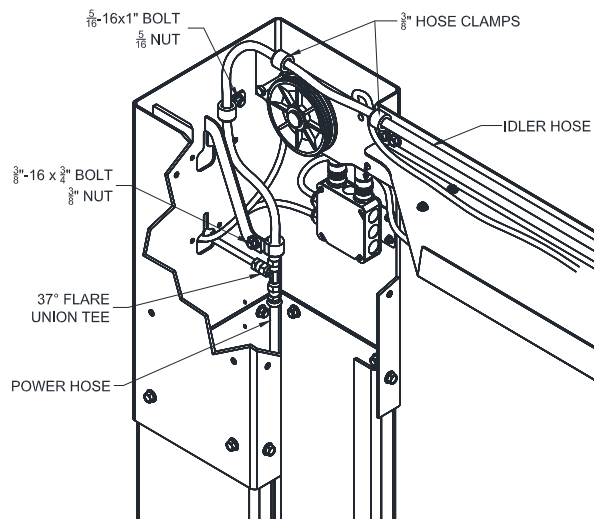

**Fig. 13b – Hose Routing, Power Side**

35) Loosely attach power column hose and idler column hose using the tee fitting (*in hardware box*)

36) Attach Power Unit Hose to power side column extension as seen in **Fig. 14a**. Connect Power unit hose to tee from **Fig. 14b** and remove slack from power column hose. Tighten loose fittings and clamps from previous step.

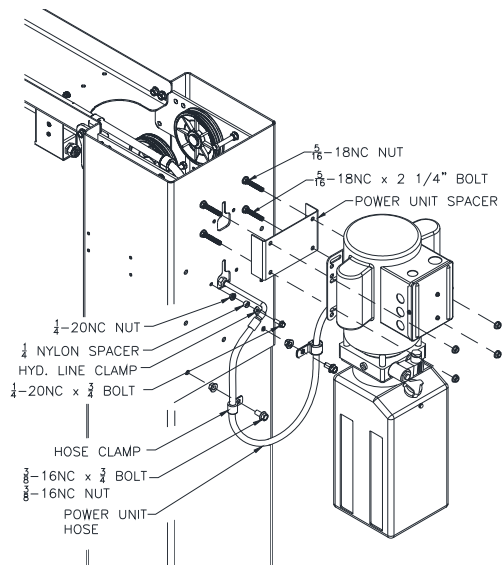

**Fig. 14a – Power Unit Hose**

37) Thread 9/16-18 O-ring elbow (*in hardware box*) into power unit. CAUTION do not damage rubber O-ring. Attach free end of power unit hose to elbow. See **Fig 14b**.

38) **BE CERTAIN ALL FITTINGS AND CONNECTIONS ARE TIGHT. IT IS THE INSTALLERS RESPONSIBILITY TO INSURE SYSTEM IS LEAK-FREE.** Fill the Power Unit with three gallons of clean 10wt anti-foam anti-rust hydraulic / Biodegradable oil or Dexron III ATF. **DO NOT USE OILS WITH DETERGENTS.**

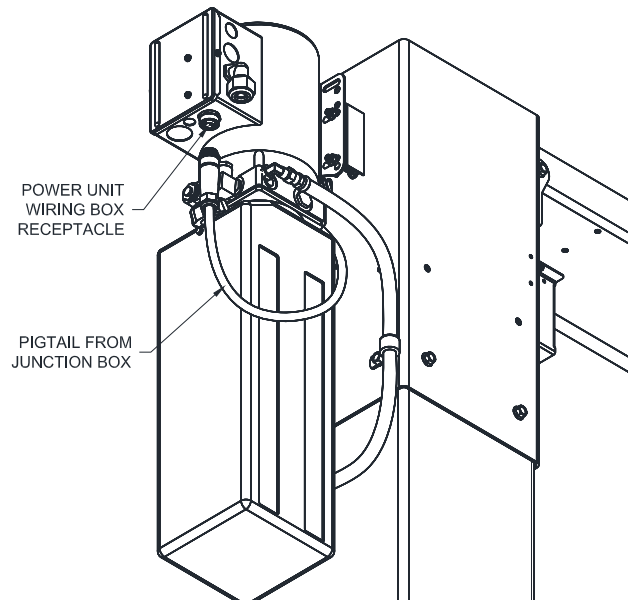

**Fig. 14b – Junction Box Connection to Power Unit**

39) Attach the junction box pigtail to the power unit receptacle. **Fig. 14b**.

## DUAL LOCK RELEASE

(TWO LOCK RELEASE CABLES WILL BE ROUTED TOGETHER THROUGH THE LIFT. ONE CABLE ATTACHES TO THE TOP OF THE POWER COLUMN LOCK RELEASE CLEVIS AND THE BOTTOM OF THE IDLER COLUMN LOCK PAWL. THE OTHER CABLE ATTACHES TO THE TOP OF THE IDLER COLUMN LOCK RELEASE CLEVIS AND THE BOTTOM OF THE POWER COLUMN LOCK PAWL)

- 40) Attach Mechanical Lock Release Cable Assembly to Power Column Lock Pawl using the 3/16" diameter x 1/2" long pin and (2) "C" clip retainers found in hardware, **Fig. 15**.
- 41) Insert threaded sleeve portion of cable assembly in slot located on tab above locking pawl, **Fig. 15**. One jam nut should be located on each side of tab. Position threaded sleeve with 1/2" of thread below tab as indicated in **Fig. 15** and tighten jam nuts.
- 42) Route opposite end of cable assembly up Power Column and into column through access slot in bottom of Column Extension. Following the path of the hydraulic hose, route cable assembly across overhead clear of moving parts and back out through access slot in bottom of idler side column extension. Attach Cable Assembly to the hydraulic hose with loosely fit wire ties.

**NOTE:** DO NOT kink cable assembly when routing. Tighten and trim wire ties after final cable adjustments have been made.

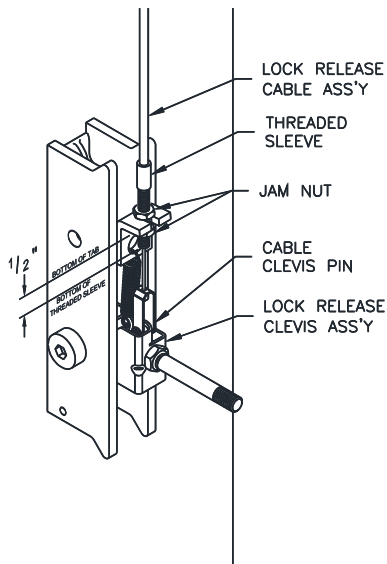

**Fig. 15 – Power Column Lock Release Assembly**

- 43) Attach Adhesive-Backed Tab to Idler Column left of the lock assembly, **Fig. 16**. Route Lock Release Cable down left side of Idler Column and secure with loosely fit wire tie to Adhesive-Backed Tab. Attach Cable clevis to 1/2" O.D. Extension Spring.

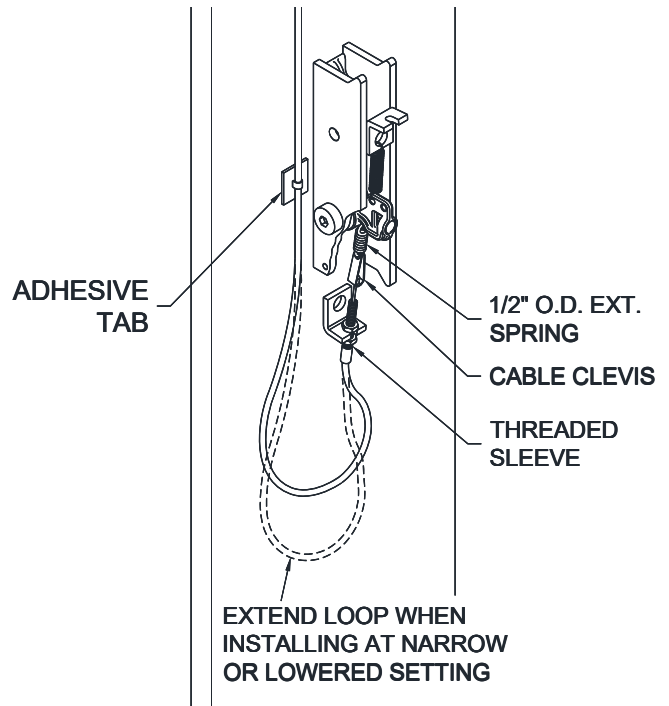

**Fig. 16 – Idler Column Lock Release Assembly**

- 44) Insert threaded sleeve portion of cable assembly in slot located on tab below lock pawl, **Fig 16**. With one jam nut located on each side of tab, adjust the threaded sleeve to begin to pull tension on the 1/2" O.D. spring. Snug jam nuts by hand.
- 45) Repeat **procedures 24 thru 28** with second Lock Release Cable routing from top of Idler Column Lock to bottom of Power Column Lock, (**Figs. 15 & 16**).

**THE LOCK RELEASE CABLE ADJUSTMENT IS NOT COMPLETE UNTIL THE LIFT HAS BEEN LOWERED AND "FINAL ADJUSTMENTS" HAVE BEEN MADE.**

## ARM INSTALLATION

- 46) Grease the arm pin or carriage arm pin hole with heavy viscous grease and install the arms. Use the grease fittings during regular monthly maintenance.
- 47) Slide the provided washer onto pin up against the inner bevel gear.
- 48) Install the provided retaining ring onto the pin with tool, **Fig. 17**.
- 49) Arm restraints should disengage when lift is fully lowered. To ensure that the arm restraint gears engage and disengage properly loosen the bolts on the large gear on the arm. Allow the small outer gear to align itself with the inner large gear and tighten the bolts.
- 50) Make sure all the arm bolts are tight. Slide all the arms out so they are fully extended making sure that the male is retained in the female.
- 51) Extend the foot pad to both extents and apply.

- 52) “anti-seize” to the three retaining rings and where the double screw makes contact with the base of the foot pad.

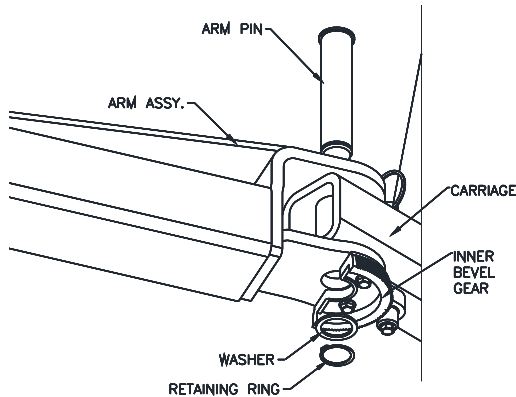

Fig. 17 –Arm Pin Keeper Install

### POWER UNIT WIRING

- 53) Connect Power Unit to suitable electrical source as shown in Fig. 18.
- 54) DO NOT PLUG EITHER PENDANT END DIRECTLY INTO POWER UNIT RECEPTACLE. This will cause a dead short and require replacing the 2 Amp x 15mm fuse located inside the motor wiring box.

**Wiring must comply with all local electrical codes.**

### ELECTRICAL TESTING

- 55) After wiring is complete, test the function of all switches (Overhead limit switch and two pendants with Raise and Lower buttons), see Fig 19.
- Raise and lower the lift from the Power Side pendant.
  - Repeat for Idler side.
  - Test the operation of the Overhead Limit Switch from each pendant control. While raising the lift, push up on the padded overhead limit switch bar. The Power Unit motor should stop while the bar is raised and restart when the bar is released. (The Overhead Limit Switch should not affect the function of the Lower button.)

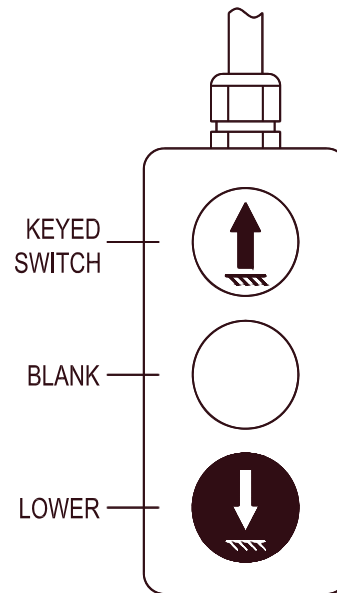

Fig. 19 – Pendant Switches

### FINAL ADJUSTMENTS

#### HYDRAULICS

- 56) Lower the lift to the floor and raise the lift approximately one foot.
- 57) Start with Idler side first. Slowly and carefully loosen the bleed plug on top of the cylinder just enough to allow the entrapped air to escape. Repeat for power side.
- 58) Raise lift 6 inches. Repeat step 48 until no air comes out of cylinder.
- 59) Pressure test hydraulic system. Energize power unit, raise lift to full rise and continue to run motor for additional 10 seconds. (NOTE: pressure relief will make a high pitch squeal sound for these 10 seconds.) Check hydraulic system for leaks.
- 60) Energize power unit again for 10 seconds. With a clean rag, wipe down both cylinder rods. (The cylinders are shipped with a small amount of clear anti-corrosive lubricant that will be forced out through the wiper when the lift reaches full rise.) **If lubricant is not wiped clean from the cylinder rod, the cylinder will appear to be leaking.**

#### SYNCHRONIZING CABLES

- 61) Raise lift and insure carriages lower into same lock position.
- 62) Adjust synchronizing cables so the tension is equal in both cables and carriages are firmly sitting on locks.
- 63) Cycle lift to ensure that locks operate simultaneously.

### LOCK RELEASE CABLE

- 64) Lower lift to the floor and snap plastic cover over Power Column lock assembly.
- 65) Pull and release Power Column lock release handle while watching Idler Column lock. Adjust lower threaded sleeve cable adjuster jam nuts on Idler Column until Idler Column lock disengages and engages fully. When properly adjusted, the idler column lock should just come to rest against the back of the column when engaged and fully out against the tab when disengaged. Tighten Idler Column lower tab jam nuts.
- 66) Remove plastic lock cover from Power Column and snap plastic cover over Idler Column lock assembly.

***(The following step is a repeat of step 60 for Idler Column lock release handle)***

- 67) Pull and release Idler Column lock release handle while watching Power Column lock. Adjust lower threaded sleeve cable adjuster jam nuts on Power Column until Power Column lock disengages and engages fully. When properly adjusted, the Power Column lock should just come to rest against the back of the column when engaged and fully out against the tab when disengaged. Tighten Power Column lower tab jam nuts.

**IMPORTANT: IF LOCK PAWLS DO NOT FULLY DISENGAGE, DAMAGE MAY RESULT TO IDLER SIDE CARRIAGE AND OR CABLE SYNCHRONIZING SYSTEM.**

### FEMALE ARM SHIM INSTALL

#### **(3-STAGE ARMS ONLY)**

- 68) Extend the arm fully and lift up on the male portion, **Fig. 20**.
- 69) Using a hammer to set, place the shim on the mouth of the female arm. Use the provide self locking set screw and 1/8" Allen head wrench to securely lock the shim in place.

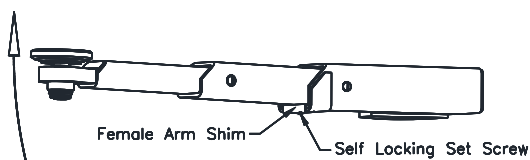

**Fig. 20 – Arm Shim, 3-Stage**

- 70) Tighten and trim wire ties.
- 71) Snap plastic cover over each lock assembly (align lock release cable with notches in lock cover flange).

### FINAL CHECKOUT PROCEDURE

- 72) Demonstrate the operation of the lift to the owner/operator/employer using a typical vehicle and review correct and safe lifting procedures using the **Lifting It Right** booklet as a guide.
- 73) Return all provided literature (including this manual) to the literature pack envelope and deliver the envelope to the owner/operator/employer.
- 74) Complete the online warranty registration (refer to the included warranty statement).

POWER UNIT ELECTRICAL CONNECTIONS

SUPPLY  
 208-240 VAC  
 60Hz, 1Ø

**Each lift should have a dedicated circuit with a 30 Amp double pole breaker or time delay fuse.**

**Wiring must comply with all local electrical codes.**

**Electrical code requires a service disconnect for this device. We suggest this service disconnect be located near the point of operation.**

**Wiring is not complete until unit has been tested, see STEP 44 for details.**

Motor Wiring Box

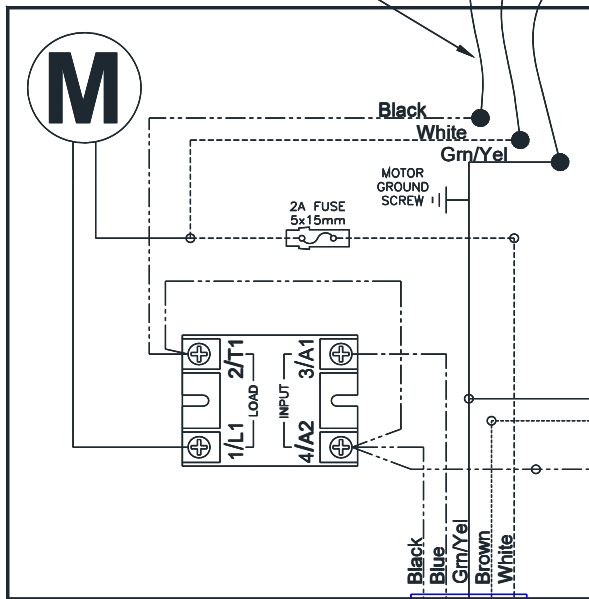

240 VAC  
 Coil

Lowering Valve  
 Solenoid  
 (on Power Unit)

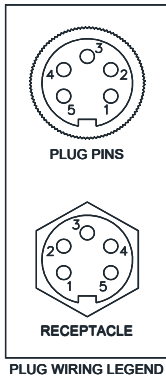

Junction Box Assembly

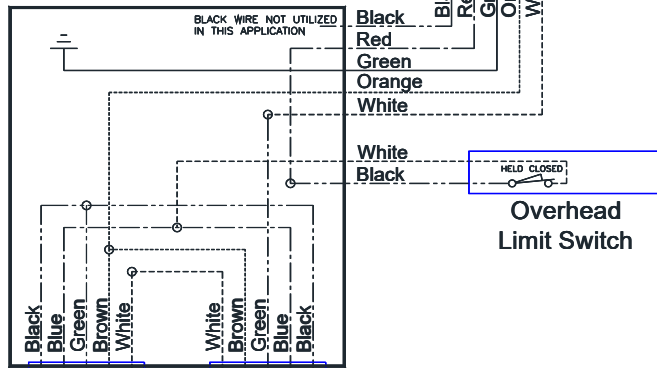

Pendant

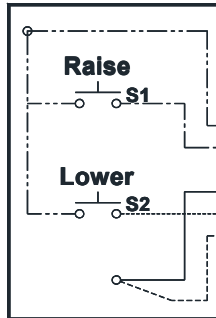

Pendant

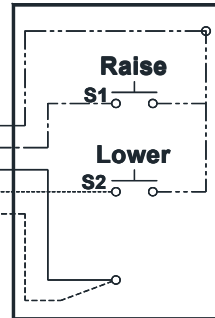

Fig. 18 – Electrical Wiring Diagram

## **OPERATION PROCEDURE**

### **SAFETY NOTICES AND DECALS**

This product is furnished with graphic safety warning labels, which are reproduced on page 3 of these instructions. Do not remove or deface these warning labels or allow them to be removed or defaced. For your safety, and the safety of others, read and understand all of the safety notices and decals included.

### **OWNER/EMPLOYER RESPONSIBILITIES**

This lift has been designed and constructed according to ANSI/ALI ALCTV standard. The standard applies to lift manufacturers, as well as to owners and employers. The owner/employer's responsibilities as prescribed by ANSI/ALI ALOIM, are summarized below. For exact wording refer to the actual standard provided with this manual in the literature pack.

**The Owner/Employer shall** ensure that lift operators are qualified and that they are trained in the safe use and operation of the lift using the manufacturer's operating instructions; ALI/SM, *ALI Lifting it Right safety manual*; ALI/ST, *ALI Safety Tips card*; ANSI/ALI ALOIM, *American National Standard for Automotive Lifts-Safety Requirements for Operation, Inspection and Maintenance*; ALI/WL Series, *ALI Uniform Warning Label Decals/Placards*; and in case of frame engaging lifts, ALI/LP-GUIDE, *Vehicle Lifting Points/Quick Reference Guide for Frame Engaging Lifts*.

**The Owner/Employer shall** establish procedures to periodically inspect the lift in accordance with the lift manufacturer's instructions or ANSI/ALI ALOIM, *American National Standard for Automotive Lifts-Safety Requirements for Operation, Inspection and Maintenance*; and the employer shall ensure that the lift inspectors are qualified and that they are adequately trained in the inspection of the lift.

**The Owner/Employer shall** establish procedures to periodically maintain the lift in accordance with the lift manufacturer's instructions or ANSI/ALI ALOIM, *American National Standard for Automotive Lifts-Safety Requirements for Operation, Inspection and Maintenance*; and the employer shall ensure that the lift maintenance personnel are qualified and that they are adequately trained in the maintenance of the lift.

**The Owner/Employer shall** maintain the periodic inspection and maintenance records recommended by the manufacturer or ANSI/ALI ALOIM, *American National Standard for Automotive Lifts-Safety Requirements for Operation, Inspection and Maintenance*.

**The Owner/Employer shall** display the lift manufacturer's operating instructions; ALI/SM, *ALI Lifting it Right safety manual*; ALI/ST,

*ALI Safety Tips card*; ANSI/ALI ALOIM, *American National Standard for Automotive Lifts-Safety Requirements for Operation, Inspection and Maintenance*; and in the case of frame engaging lift, ALI/LP-GUIDE, *Vehicle Lifting Points/Quick Reference Guide for Frame Engaging Lifts*; in a conspicuous location in the lift area convenient to the operator.

### **IMPORTANT SAFETY INSTRUCTIONS**

When using your garage equipment, basic safety precautions should always be followed, including the following:

1. Read all instructions.
2. Care must be taken as burns can occur from touching hot parts.
3. To reduce the risk of fire, do not operate equipment in the vicinity of open containers of flammable liquids (gasoline).
4. Keep hair, loose clothing, fingers, and all parts of body away from moving parts.
5. Use only as described in this manual. Use only manufacturer's recommended attachments.
6. ALWAYS WEAR SAFETY GLASSES. Everyday eyeglasses only have impact resistant lenses, they are not safety glasses.

### **SAVE THESE INSTRUCTIONS**

## **LIFTING A VEHICLE**

- 1) Ensure that the lifting arms are parked, out to full drive thru position.
- 2) Center the vehicle between the columns in the service bay and position the vehicle's center of gravity midpoint between the columns. NOTE: the center of gravity is based on the weight distribution and is not the same as the center point of the vehicle.

**DO NOT EXCEED 2500 POUNDS PER ARM.**

**DO NOT ATTEMPT TO LIFT THE VEHICLE WITH ONLY TWO ARMS, AS THIS WILL VOID THE WARRANTY**

**ENSURE THAT THE HIGHEST POINT ON THE VEHICLE WILL CONTACT THE OVERHEAD LIMIT SWITCH BAR.**

**DO NOT PLACE THE VEHICLE IN THE SERVICE BAY BACKWARDS.**

**REFER TO THE VEHICLE MANUFACTURERS SERVICE MANUAL, TECHNICAL BULLETINS, "VEHICLE LIFTING POINTS GUIDE" (ALI/LP-GUIDE) OR OTHER PUBLICATIONS TO LOCATE THE RECOMMENDED LIFTING POINTS.**

- 3) Position the arms and adapters so all four pads contact the vehicle simultaneously.

**The vehicle should remain level during lifting.**

- 4) Raise the lift until all four wheels are off the ground. Test the stability of the vehicle by attempting to rock the vehicle. Check adapters for secure contact with vehicle lift points. If the vehicle seems unstable, lower the lift and readjust the arms. If the vehicle is stable, raise the vehicle to a height a few inches above the desired working height.
- 5) Lower the vehicle until the safety locks on both columns engage. The vehicle should remain level when both locks are engaged. If one side engages and the other continues to descend, stop lowering the vehicle, raise it several inches, and try again to engage both locks.

**Always lower lift into locks before entering the area beneath the vehicle.**

**Always use safety stands when removing or installing heavy components.**

## **LOWERING A VEHICLE**

- 1) Ensure that the area under the vehicle is clear of personnel and tools.
- 2) Raise the vehicle until both locks are free.
- 3) Disengage the locks by pulling and holding the lock release lever.
- 4) Lower the vehicle by depressing the Lower button.
- 5) Continue to lower the vehicle until the carriages stop against the base plate. Retract the extension arms, and park them.

## **LOSS OF POWER**

If for any reason the lift will not raise off the locks or the locks will not retract, consult factory authorized personnel.

**DO NOT OVERRIDE ANY SAFETY FEATURE IN AN ATTEMPT TO LOWER THE LIFT.**

## **MAINTENANCE**

To avoid personal injury, permit only qualified personnel to perform maintenance on this equipment. Maintenance personnel should follow lockout/tagout instructions per ANSI Z244.1.

The following maintenance points are suggested as the basis of a routine maintenance program. The actual maintenance program should be tailored to the installation and include a record of each planned maintenance activity and repair maintenance activity performed. Refer to the maintenance section of the ANSI/ALI ALOIM booklet (blue book) provided with the lift.

- If lift stops short of full rise or chatters, check fluid level and bleed both cylinders per Installation Instructions.
- Replace all Safety, Warning or Caution Labels if missing or damaged (**See *Installation instructions page 3.***)

### **Daily**

- Keep lift components clean.
- Check for loose or broken parts.
- Check hydraulic system for fluid leaks.
- Check adapters for damage or excessive wear. Replace as required with genuine Challenger Lifts parts.
- Check lock release activation. When properly adjusted, the idler column lock should rest firmly against the back of the column when engaged and against the spring mount tab when disengaged.

### **Weekly**

- Check synchronizer cables and sheaves for wear. Replace as required with genuine Challenger Lifts parts.
- Check synchronizer cable tension per Installation Instructions. Adjust if necessary.

### **Monthly**

- Torque concrete anchor bolts to 80 ft-lbs.
- Visually inspect concrete floor for cracks and/or spalls within 12" of base plate
- Check overhead shutoff switch. While raising lift, operate overhead shutoff bar. Power Unit motor should stop when bar is raised.
- Lubricate carriage slide tracks with heavy viscous grease. (Grease all (4) corners of both columns.)
- Lubricate arm using the grease fittings.

**If any problems are encountered, contact your local service representative.**

# PARTS BREAKDOWN

Fig A. Column & Overhead

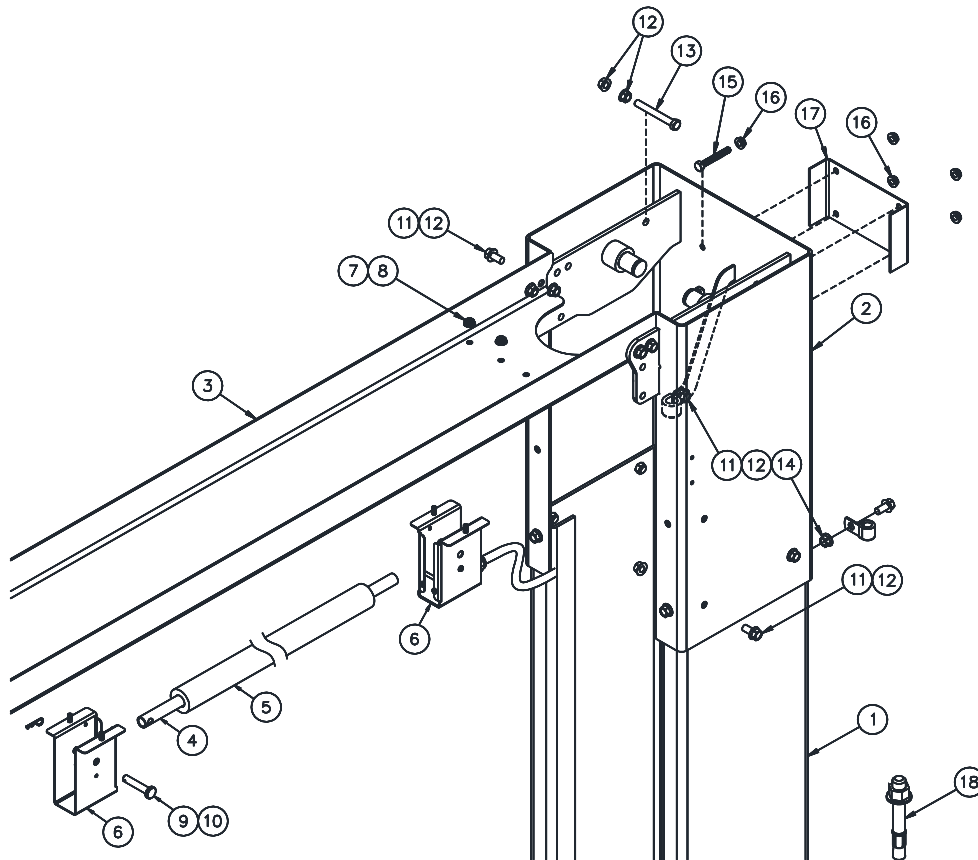

ITEM #	PART #	QTY/LIFT	DESCRIPTION
1	A2010 - P	1	POWER COLUMN WELD
	A2010 - I	1	IDLER COLUMN WELD
2	A2071 - 57 - 0	2	COLUMN EXTENSION WELD - CL10
	A2071 - 57 - 2		COLUMN EXTENSION WELD - CL10-2
	A2071 - 57 - 3		COLUMN EXTENSION WELD - CL10-3
3	A2060	1	OVERHEAD CHANNEL
4	A2067	1	SHUTOFF BAR
5	31129	1	SHUTOFF BAR CUSHION
6	B2064 - 01	1	LIMIT SWITCH PACKAGE (INCLUDES SWITCH w/ CORD, BOTH BRACKETS, & ITEMS 7-10)
7	B2065-3	4	M6 x 14mm PHILLIPS PAN HEAD SCREW
8	B2065-4	4	M6 SERRATED FLANGE HEX NUT
9	B2065-5	1	CLEVIS PIN 10mm x 55 Lg.
10	GJY12-3	1	HAIRPIN COTTER
11	A1153	24	3/8-16NC HEX.FLG.HD.C.S X 3/4" Lg.
12	A1154	32	3/8-16NC HEX.FLG.NUT
13	A2159	4	3/8-16NC x 3" Lg HEX HEAD C.S. Gr.5
14	A1122 - 12	10	3/8" HOSE CLAMP
15	31190	4	5/16"-18 x 2 1/4" HEX BOLT
16	31189	8	5/16-18 NUT
17	A2077	1	DPC POWER UNIT BRACKET
18	31058	14	ANCHOR BOLT, 3/4 x 5-1/2" Lg.

Replace all worn, damaged, or broken parts approved by **Challenger Lifts Inc.** or with parts meeting **Challenger Lifts Inc.** specifications.  
 Contact your local Challenger Lifts Parts Distributor for pricing and availability.  
 (Call Challenger Lifts Inc. (502) 625-0700 for the Parts Distributor in your area)



**PARTS BREAKDOWN** (continued)

**Fig B. Lock**

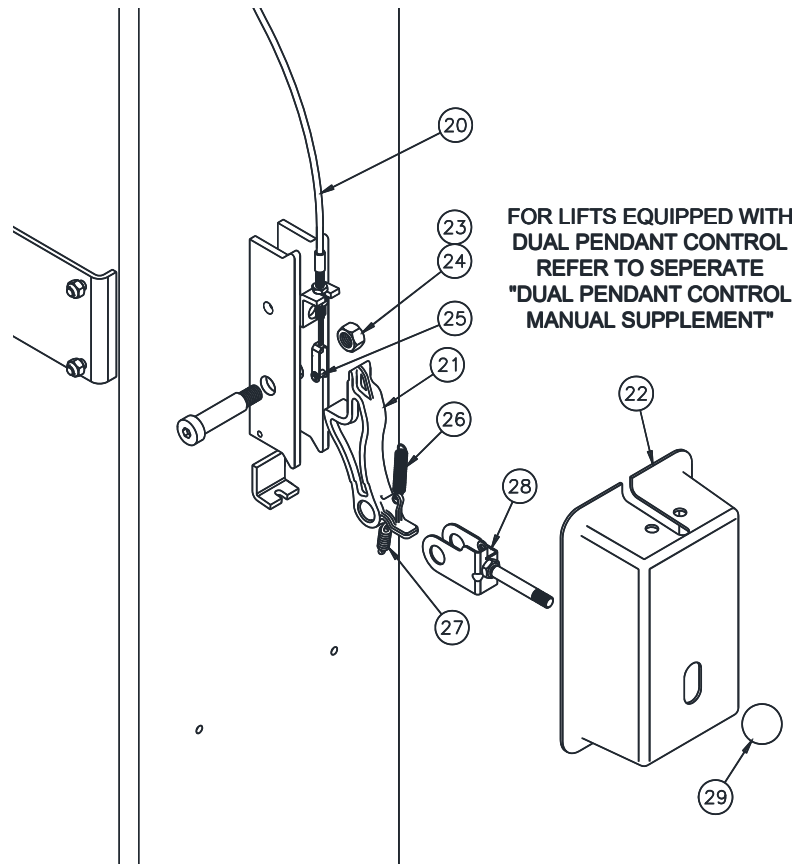

ITEM #	PART #	QTY/LIFT	DESCRIPTION
20	A2135-0	2	LOCK RELEASE CABLE ASSEMBLY - CL10
	A2135-2		LOCK RELEASE CABLE ASSEMBLY - CL10-2
	A2135-3		LOCK RELEASE CABLE ASSEMBLY - CL10-3
21	B1140	2	LOCK PAWL
22	A1133	2	LOCK COVER
23	30020	2	LOCK PIN (5/8 x 1 1/2" Lg. SHOULDER BOLT)
24	37013	2	LOCK PIN RETAINER (1/2-13NC HEX LOCK NUT)
25	37119	2	CLEVIS PIN KIT
26	A1131	2	LOCK SPRING (3/8" O.D.)
27	A1132	2	CABLE SPRING (1/2" O.D.)
28	A1141	2	LOCK RELEASE CLEVIS ASSEMBLY
29	36096	2	BALL HANDLE

Replace all worn, damaged, or broken parts approved by **Challenger Lifts Inc.** or with parts meeting **Challenger Lifts Inc.** specifications.

Contact your local Challenger Lifts Parts Distributor for pricing and availability. (Call Challenger Lifts Inc. (502) 625-0700 for the Parts Distributor in your area)

**PARTS BREAKDOWN** (continued)

*Fig C. Hydraulics*

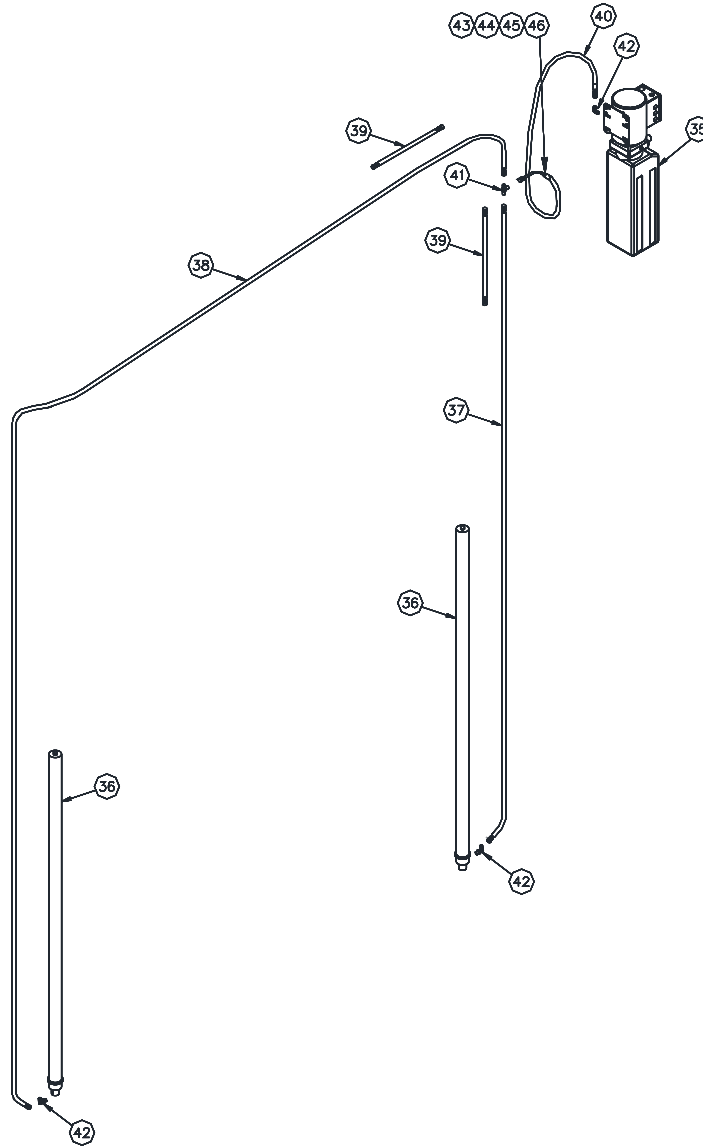

ITEM #	PART #	QTY/LIFT	DESCRIPTION
35			POWER UNIT SEE PARTS BREAKDOWN FIG. E ELECTRICAL
36	16138R	2	CYLINDER (68" STROKE RAM)
	16138R-QC		CYLINDER (68" STROKE RAM), QUICK CYCLE
37	A2127-57P	1	POWER HOSE (STD. LENGTH 120")
38	A2127-I	1	IDLER HOSE (STD. LENGTH 287")
39	39101-024	3	2 FT. HOSE EXTENSION (CL10-2, LENGTH 24")
	39101-036		3 FT. HOSE EXTENSION (CL10-3, LENGTH 36")
40	A2127-PU	1	POWER UNIT HOSE (STD LENGTH 73 1/2")
41	39103	1	37 Degree UNION TEE
42	16167	3	9/16-18 STRAIGHT THREAD ELBOW
43	31025	1	Hyd. LINE CLAMP
44	12748	1	1/4 x 1/4 NYLON SPACER
45	A2125	1	1/4-20 x 3/4 HEX FLANGE HEAD BOLT
46	40085	1	1/4-20 HEX FLANGE NUT

Replace all worn, damaged, or broken parts approved by **Challenger Lifts Inc.** or with parts meeting **Challenger Lifts Inc.** specifications.  
 Contact your local Challenger Lifts Parts Distributor for pricing and availability.  
 (Call Challenger Lifts Inc. (502) 625-0700 for the Parts Distributor in your area)

**PARTS BREAKDOWN** (continued)

*Fig D. Synchronizer*

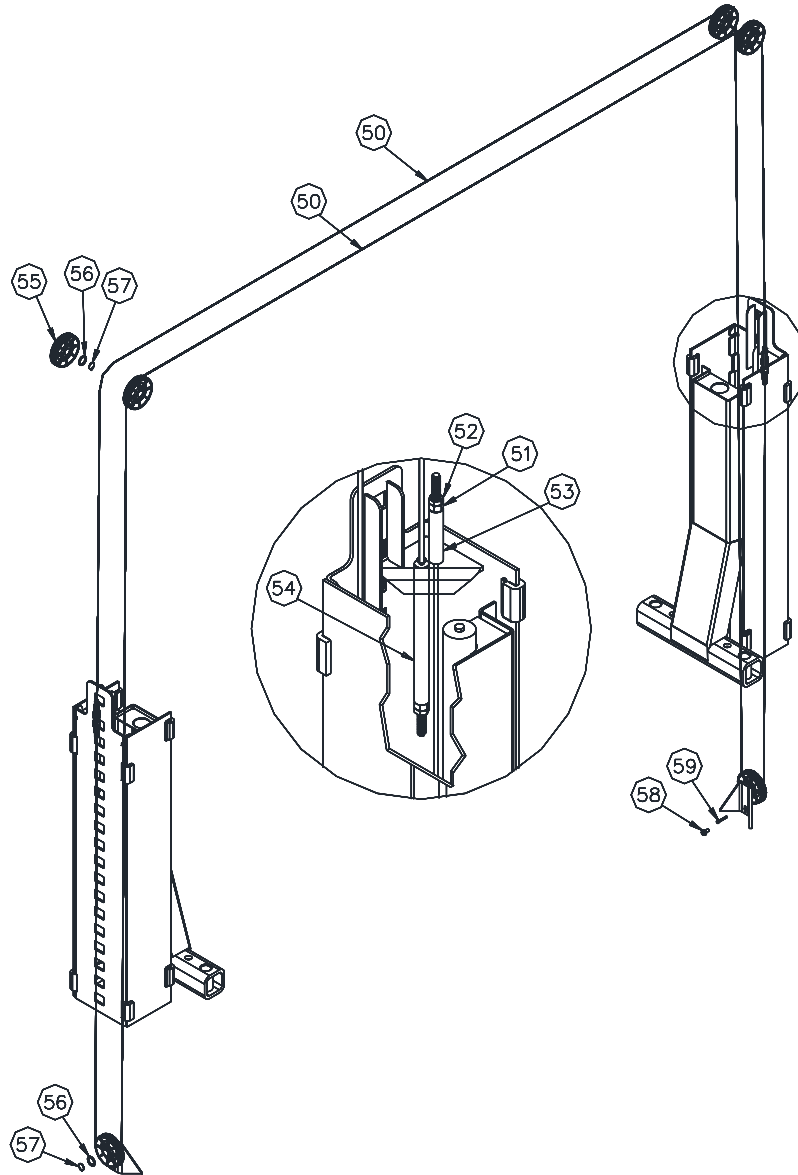

ITEM #	PART #	QTY/LIFT	DESCRIPTION
50	A2003-0	1	SYNCHRONIZER CABLE - CL10
	A2003-2		SYNCHRONIZER CABLE - CL10-2
	A2003-3		SYNCHRONIZER CABLE - CL10-3
51	A2116	4	5/8-11NC HEX NUT
52	A2117	4	5/8-11NC HEX JAM NUT
53	A2118	2	4 1/2" TAKE UP TUBE (FOR 11'-6 1/2" WIDTH)
54	A2119	2	12" TAKE UP TUBE (FOR 11'-2", 13'-2", & 14'-2" HEIGHTS)
55	36025	6	SHEAVE ASSEMBLY (5" DIA. X 5/16" GROOVE)
56	36013	10	1" I.D. SPACER WASHER
57	36014	2	1" EXT. RETAINING RING
58	A1153	2	3/8-16 x 3/4" LOCK. HEX FLG. HEAD, C.S
59	A2158	2	1/4 DIA. x 1 3/4" Lg CLEVIS PIN

Replace all worn, damaged, or broken parts approved by **Challenger Lifts Inc.** or with parts meeting **Challenger Lifts Inc.** specifications. Contact your local Challenger Lifts Parts Distributor for pricing and availability. (Call Challenger Lifts Inc. (502) 625-0700 for the Parts Distributor in your area)

**PARTS BREAKDOWN (continued)**

*Fig E. Electrical*

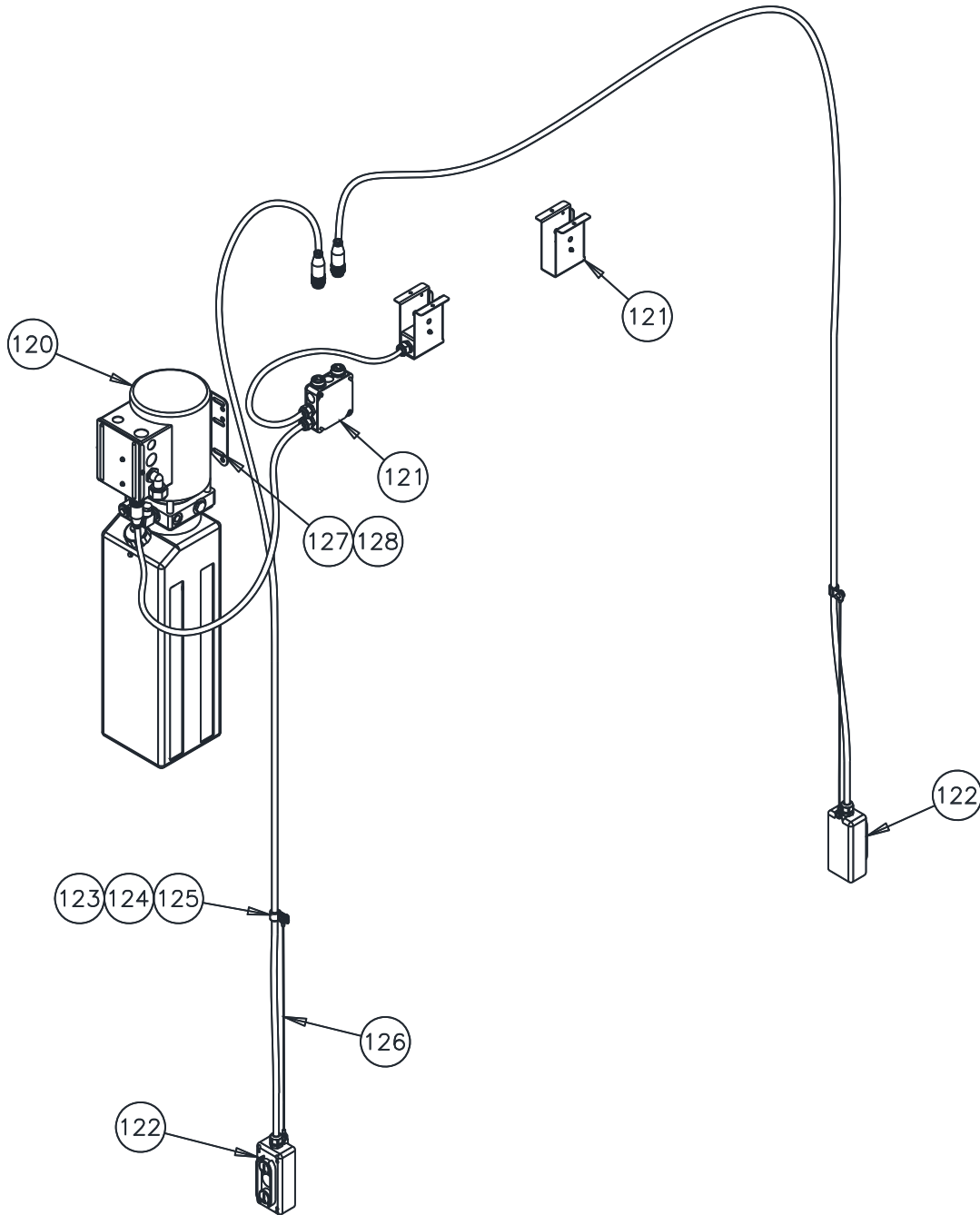

ITEM #	PART #	QTY/LIFT	DESCRIPTION
120	A1207-19	1	STANDARD DPC POWER UNIT, 1ph, 60Hz, 208-240V
	AB-10397		QUICK CYCLE DPC POWER UNIT, 1ph, 60Hz, 208-240V
121	A1208	1	JUNCTION BOX ASSEMBLY (INCLUDING OVERHEAD LIMIT SWITCH AND PIVOT BRACKET)
122	A1206-10-IX	2	REPLACEMENT PENDANT ASSEMBLY
123	A1122-9	4	CABLE CLAMP, 1/2" I.D.
124	10335	2	5/16-18 x 3/8 Lg. PHILLIPS PAN HEAD SCREW
125	31331	2	5/16 SPLIT LOCK WASHER
126	A1206-10-20	2	LANYARD STRAP ASSEMBLY (INCLUDING 3/8 PIN AND E-CLIP)
127	A1069	4	5/16-18 x 1" Lg. SERRATED FLANGE HEX HEAD SCREW
128	4100237	8	5/16-18 SERRATED FLANGE HEX NUT

Replace all worn, damaged, or broken parts approved by **Challenger Lifts Inc.** or with parts meeting **Challenger Lifts Inc.** specifications.  
 Contact your local Challenger Lifts Parts Distributor for pricing and availability.  
**(Call Challenger Lifts Inc. (502) 625-0700 for the Parts Distributor in your area)**

Model CL10 with Dual Pendant Control  
Installation, Operation, and Maintenance  
**PARTS BREAKDOWN** (continued)

**Fig F. Carriage & 3-Stage Arm Pack (B2202SD)**

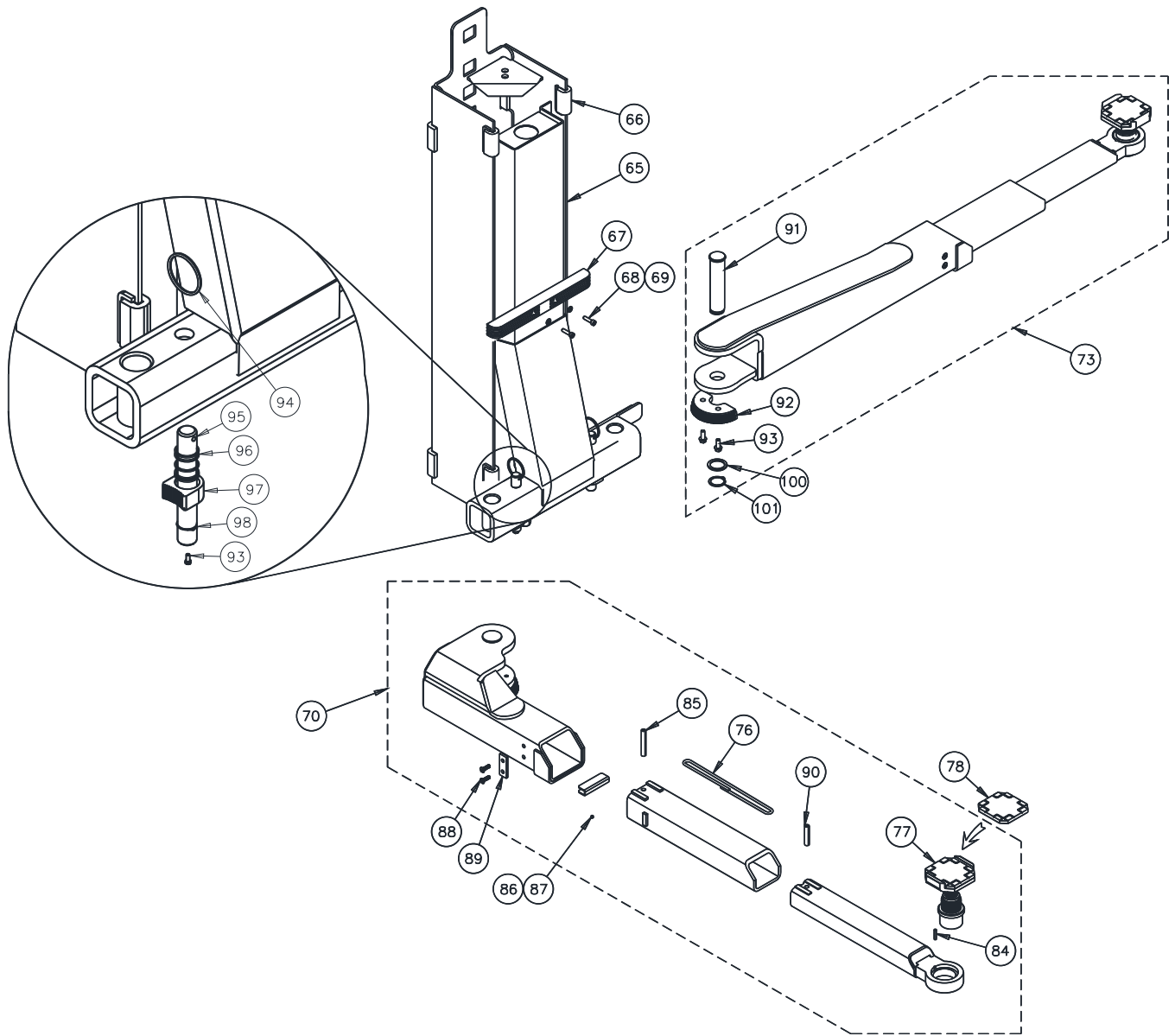

Replace all worn, damaged, or broken parts with parts approved by **Challenger Lifts Inc.** or with parts meeting **Challenger Lifts Inc.** specifications.  
Contact your local Challenger Lifts Parts Distributor for pricing and availability.  
(Call **Challenger Lifts Inc.** (502) 625-0700 for the Parts Distributor in your area)

Model CL10 with Dual Pendant Control  
Installation, Operation, and Maintenance

**PARTS BREAKDOWN** (continued)

ITEM #	PART #	QTY/LIFT	DESCRIPTION
65	B2026-57	2	CARRIAGE WELD (57" LADDER)
66	31023	16	SLIDE BLOCK
67	B2026-2	2	RUBBER DOOR GUARD
68	X10-088	4	M8x1.25x30mm Lg. SHCS
69	X10-087	8	M8 WASHER
70	B2203S-PD	1	FRONT ARM ASSEMBLY (POWER
	B2203S-ID	1	FRONT ARM ASSEMBLY (IDLER)
73	B2204SD	2	REAR ARM ASSY
76	CS1020-05	4	STOP LOOP
77	B2270	4	FOOT PAD ASSEMBLY (items 78-83), 55mm STROKE
78	A1104-H	4	RUBBER INSERT
84	B2211	4	ROLL PIN, 6mm DIA x 30mm Lg.
85	B2202-02	4	ROLL PIN, 12mm DIA x 80mm Lg.
86	CS1020-03-01	4	FEMALE ARM SHIM
87	CS1020-03-02	4	M6 x 1 x 6mm Lg. SELF-LOCKING SET SCREW
88	17350	8	M8 x 10mm Lg. FLAT HEAD BOLT
89	CS1020-04	4	STOP BLOCK
90	B2202-01	4	ROLL PIN, 12mm DIA x 60mm Lg.
91	B1078	4	ARM PIN WELD
92	A1070TC	4	INNER GEAR, BEVELED
93	B1068	12	M10x1.5x25mm Lg. HEX FLANGE HEAD BOLT
94	A1075	4	PULL RING
95	A1073C	4	ARM RESTRAINT SHAFT
96	31109	4	COMPRESSION SPRING (RESTRAINT SHAFT)
97	A1072TC	4	OUTER GEAR, BEVELED
98	36014	4	1" EXTERNAL RETAINING RING
99	A1077TC	4	ARM RESTRAINT SHAFT ASSEMBLY (items 93-98)
100	B2203S-01D	4	39mm ID, 51mm OD WASHER
101	B1083	4	38mm EXTERNAL RETAINING RING
	B2202SD	1	ARM PACK, CL10, 3-STAGE

Replace all worn, damaged, or broken parts with parts approved by **Challenger Lifts Inc.** or with parts meeting **Challenger Lifts Inc.** specifications.  
Contact your local Challenger Lifts Parts Distributor for pricing and availability.  
(Call **Challenger Lifts Inc.** (502) 625-0700 for the Parts Distributor in your area)

## **NOTES**

## **REVISIONS**

- 2019/11/21 – ADDED ANCHOR BOLTS TO THE PBD. CORRECT THE SYNC CABLE PART NUMBERS AND THE COLUMN WELD PART NUMBERS IN THE PBD. UPDATED SAFETY REQUIREMENTS FOR INSTALLATION AND SERVICE. ADDED STEP TO CHECK THE ARM STOP BOLTS TO MAKE SURE THEY ARE TIGHT.
- 2020/01/02 – CL10 MANUAL REVISED FOR 6" AJUSTABILITY, SHEAVE CONFIGURATION, AND HOSE ROUTING.
- 2021/09/03 – REORDERED SPEC PAGE, LATCH CHANGED TO LOCK, OUTDOOR INSTALLATION PROHIBITED, UPDATED ARM ASSEMBLY AND FOOTPAD IN PBD.
- 2022/04/01 – UPDATED CLEVIS BAR ON LOCK DIAGRAMS
- 2023/11/13 – UPDATED ANSI/ALI REFERENCE MATERIAL, UPDATED ANCHOR REFERENCE. Pg. 5.
- 2024/03/14 – ADDED ANSI STANDARD REFERENCE STATEMENT SECTION. PG. 4.