

CL Challenger Lifts

**2200 lb Shop Crane (CLHMSC-220)
4400 lb Shop Crane (CLHMSC-440)**

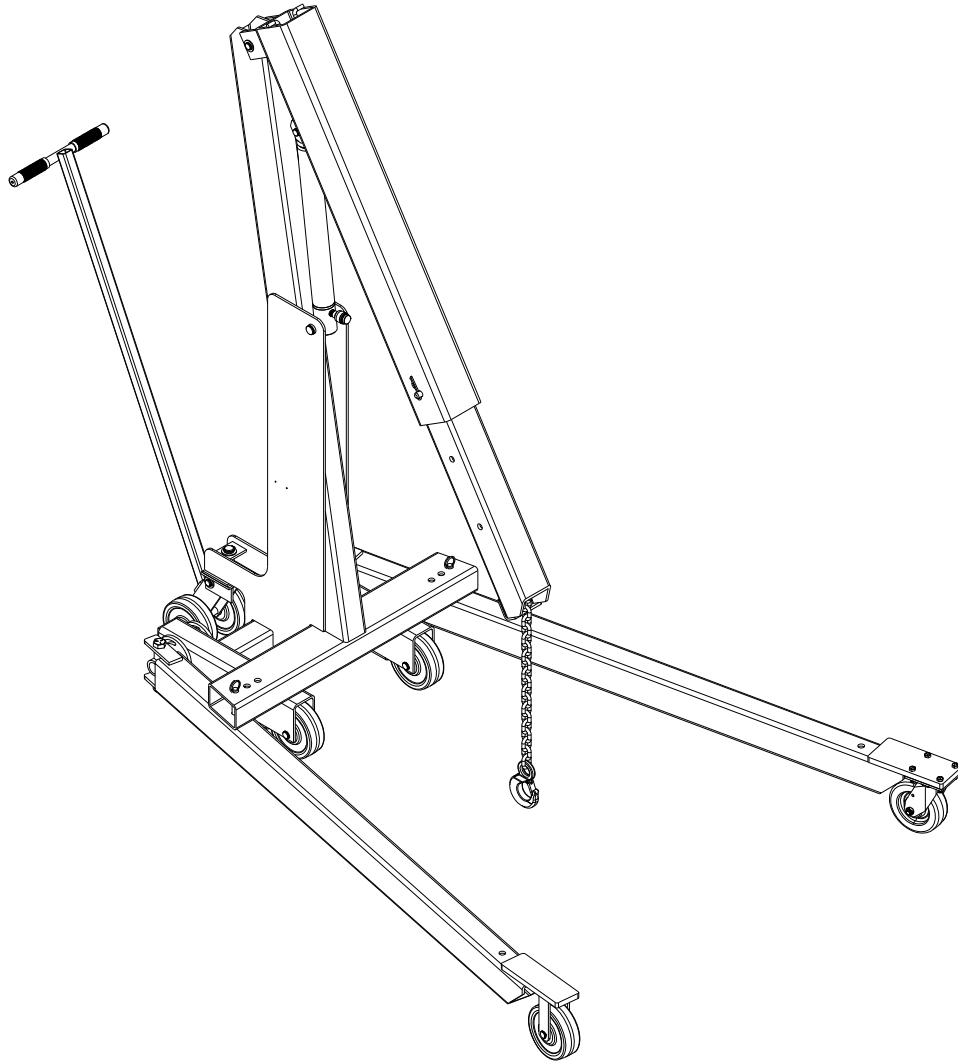

2311 South Park Rd. Louisville, Kentucky 40219

Email: sales@challengerlifts.com

Web site: www.challengerlifts.com

Office 800-648-5438 / 502-625-0700 Fax 502-587-1933

**IMPORTANT: READ THIS MANUAL COMPLETELY BEFORE
INSTALLING or OPERATING LIFT**

Table of Contents

Signal Words	3
Receiving Inspection	3
Introduction	4
Specifications	4
Component Identification	5
Assembly Instructions	6
1. Hydraulic Pump Installation	6
2. Hydraulic Cylinder Installation	10
Operating Instructions	12
1. Adjusting the Boom.....	12
2. Adjusting the Legs	13
3. Positioning the Crane	13
4. Securing the Load.....	13
5. Adjusting Load Height.....	14
6. Moving the Load	14
7. Folding Legs for Storage	15
Maintenance and Lubrication Instructions	16
Structural Inspection	17
Troubleshooting	19

Signal Words

Signal words call attention to a safety message or messages, or a property damage message or messages, and designate a degree or level of hazard seriousness. The signal words are “DANGER”, “WARNING”, “CAUTION”, and “NOTICE”.

DANGER: Indicates a hazardous situation, which, if not avoided, will result in death or serious injury. This signal word is to be limited to the most extreme situations.

WARNING: Indicates a hazardous situation, which, if not avoided, could result in death or serious injury.

CAUTION: Indicates a hazardous situation, which, if not avoided, could result in minor or moderate injury.

NOTICE: Indicates a hazardous situation, which, if not avoided, could result in non-personal injury.

Receiving Inspection

Before attempting to operate this equipment, thoroughly read and understand this manual. Completely remove all tape and packaging. Inspect the equipment immediately upon delivery. If shipping damage is evident, inform the delivering carrier immediately and contact the manufacturer using the contact information on the back cover of this manual.

Introduction

Owner and/or Operator Responsibilities

The owner and/or operator must have an understanding of the manufacturer’s operating instructions and warnings before using this equipment. Personnel involved in the use and operation of equipment shall be careful, competent, trained, and qualified in the safe operation of the equipment and its proper use when servicing motor vehicles and their components. Warning information should be emphasized and understood.

The owner/manager must make this manual available to all personnel using this equipment at your direction. They must read and understand the contents of this manual. If the operator is not fluent in English, the manufacturer’s instructions and warnings shall be read to and discussed with the operator in the operator’s native language by the purchaser/owner, making sure that the operator comprehends its contents and observes the proper procedures for use of this equipment.

Owner and/or operator must study and maintain for future reference the manufacturer’s instructions. Owner and/or operator are responsible for keeping all warning labels and instruction manuals legible and intact. Replacement labels and literature are available from the manufacturer.

Specifications

	CLHMSC-220	CLHMSC-440
Capacity (retracted).....	2,200 lbs.	4,400 lbs.
Capacity (centered).....	1,900 lbs.	3,800 lbs.
Capacity (extended).....	1,650 lbs.	3,300 lbs.
Maximum Boom Height (retracted).....	114”	119”
Maximum Boom Height (extended).....	125”	130”
Overall Boom Height (horizontal).....	83”	84”
Boom Reach (retracted).....	48”	50-3/4”
Boom Reach (extended).....	33”	35-3/4”
Overall Length.....	82”	82”
Minimum Throat Width.....	22”	22”
Leg Length (inside).....	55”	55”
Inside Leg Width (3 Positions).....	22”	22”
	36”	36”
	50”	50”
Leg Height.....	8-1/8”	8-1/8”
Wheel Diameter.....	6”	6”
Weight.....	540 lbs.	640 lbs.
Maximum Air Pressure (if equipped with air pump).....	200 psi	200 psi
Minimum Air Pressure (if equipped with air pump).....	95 psi	95 psi

Component Identification

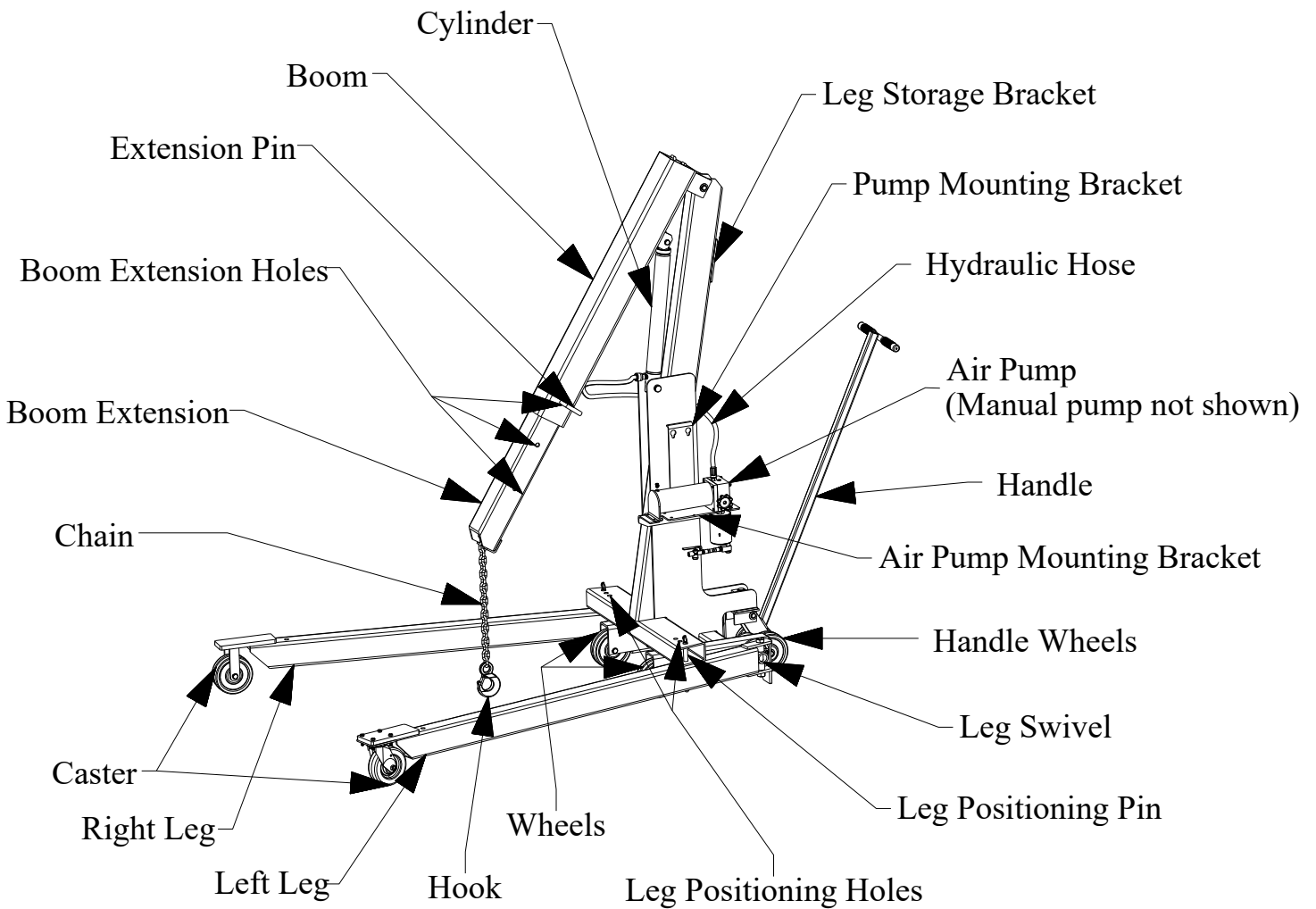

Assembly Instructions

1. Hydraulic Pump Installation

Both crane models are available with either a manually powered pump or an air powered pump. Please check Table 1 below to ensure you have the correct pump model before continuing with the installation.

Table 1

Crane Model #	Manual Pump Model #	Air Pump Model #
CLHMSC-220	MP-50	AHP-50
CLHMSC-440	MP-100	AHP-100

Once you have verified that you have the correct model of hydraulic pump for your crane, follow the instructions in the appropriate section below to mount the pump on the crane. **WARNING!** *Use of the wrong pump model on the crane can cause the crane to be overloaded resulting in possible damage to the crane and/or sudden dropping of the supported load. ONLY use the pump model provided with your crane or an exact replacement from the crane manufacturer. NEVER use an aftermarket pump on the crane.*

a. Manual Pump:

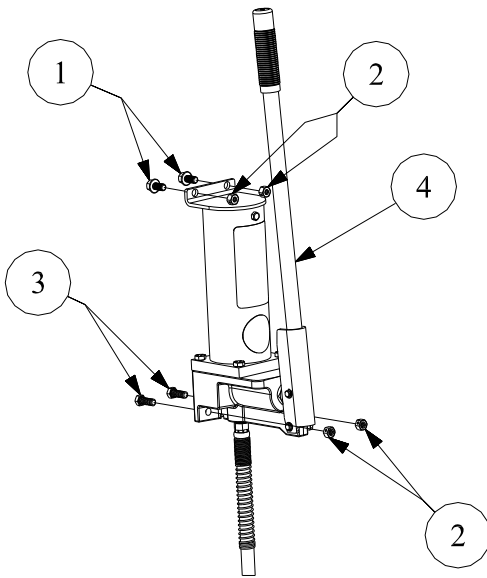

Figure 1

1. Insert the two 3/8" X 3/4" flange head bolts [#1] through the holes in the pump [#4] as shown in Figure 1 and start two 3/8" nuts [#2] onto the bolts. Only start the nuts [#2] one or two turns onto the bolts [#1].
2. On the opposite end of the pump [#4], insert two 3/8" X 1" bolts [#3] and start a 3/8" nut [#2] on each bolt. See Figure 1. Only start the nuts [#2] one or two turns onto the bolts [#3].

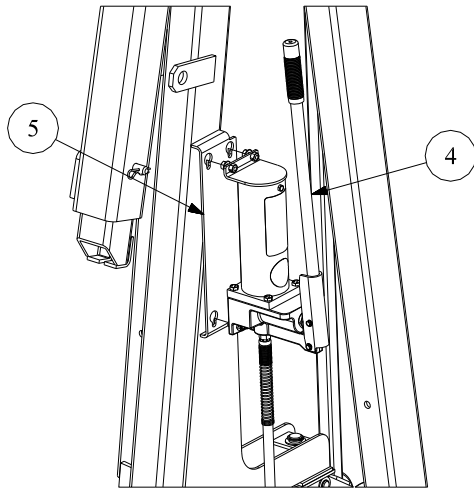

Figure 2

3. Align the pump [#4] with the keyhole slots in the bracket [#5] on the side of the crane as shown in Figure 2.
4. Move the pump [#4] against the bracket [#5] ensuring that the heads of all the bolts pass through the keyhole slots in the bracket [#5].
5. Once the heads of all the bolts [#1 & #3] have passed through the keyhole slots in the bracket [#5] lower the pump [#4] so the bolts [#1 & #3] rest in the bottom of the slots.
6. Tighten all four 3/8" nuts [#2] to secure the pump [#4].

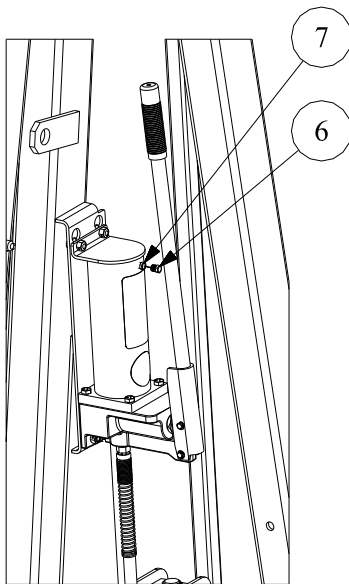

Figure 3

7. Remove the shipping plug [#6] from the pump [#4] as shown in Figure 3.
8. Check the oil level in the pump. The oil level should be 2" to 3" from the bottom of the hole. If the oil level is low, add hydraulic fluid equivalent to Conoco MV22 until the level is 2" to 3" from the bottom of the hole.
9. Install the breather vent plug [#7], provided with the crane, in the pump [#4] in the same hole the shipping plug [#6] was removed from in Step 7.

b. Air Pump:

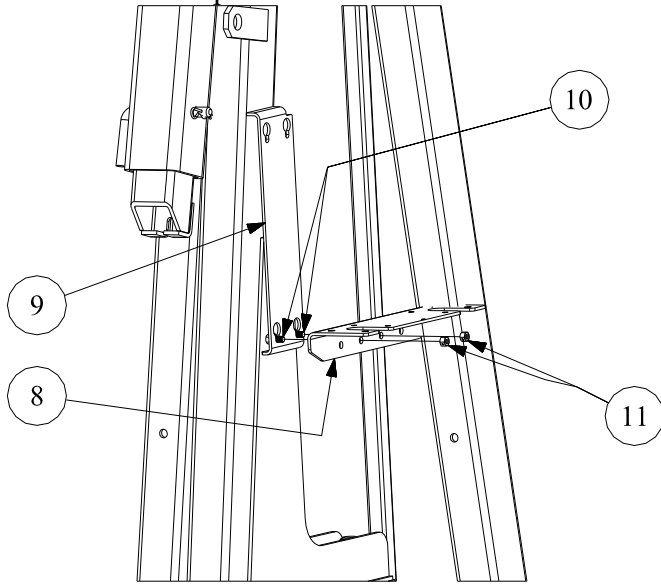

Figure 4

1. Attach the pump bracket [#8] to the bracket [#9] on the side of the crane using two 3/8" X 3/4" flange head bolts [#10] and two 3/8" nuts [#11] as shown in Figure 4. Be sure to attach the pump bracket [#8] to the bottom set of keyhole slots in the bracket [#9].

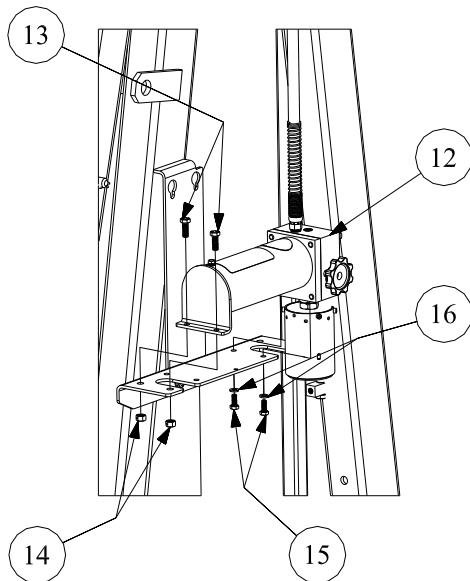

Figure 5

2. Mount the air pump [#12] to the pump bracket [#11] as shown in Figure 5. Use two 3/8" X 1" bolts [#13] and 3/8" nuts [#14] to secure the reservoir end of the air pump [#12]. The opposite end of the air pump [#12] is attached to the pump bracket [#11] using two 5/16" X 3/4" bolts [#15] and two 5/16" lock washers [#16]. The 5/16" X 3/4" bolts [#15] thread into tapped holes in the air pump [#12].

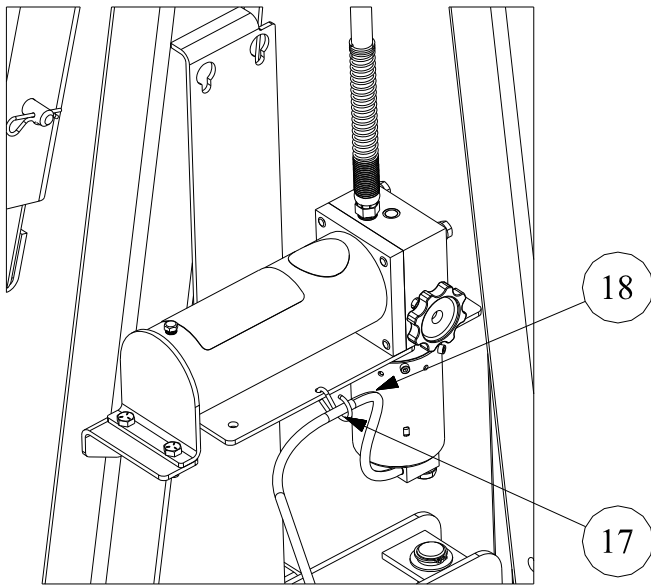

Figure 6

3. Attach the S-hook [#17] to the hole in the pump bracket [#11] as shown in Figure 6.
4. Route the air hose [#18] through the S-hook [#17]. The S-hook [#17] can be closed around the air hose [#18], if desired. Be careful to not pinch or cut the air hose [#18] when closing the S-hook [#17]. Otherwise, the S-hook [#17] can be left open so the air hose [#18] can be inserted or removed from the hook as desired. The purpose of the S-hook [#17] is to provide a location to hang the air hose [#18] that prevents it from dragging on the floor.

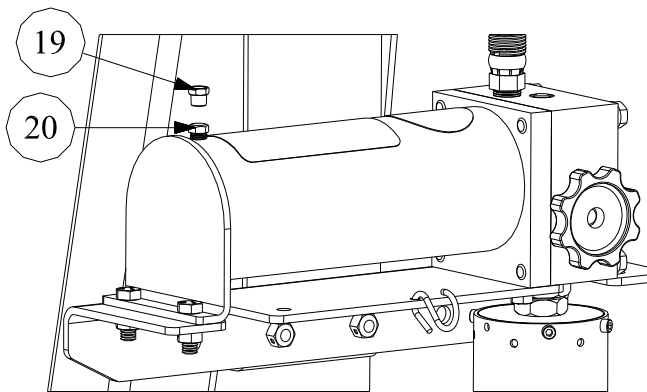

Figure 7

5. Remove the shipping plug [#19] from the pump [#12] as shown in Figure 7.
6. Check the oil level in the pump. The oil should be 1" to 1-1/4" from the bottom of the hole. If the oil level is low, add hydraulic fluid equivalent to Conoco MV22 until the level is 1" to 1-1/4" from the bottom of the hole.
7. Install the breather vent plug [#20], provided with the crane, in the pump [#12] in the same hole the shipping plug [#19] was removed from in Step 5.

2. Hydraulic Cylinder Installation

The directions below describe how to install the cylinder on the crane. The hydraulic cylinder on either model is installed in the same manner.

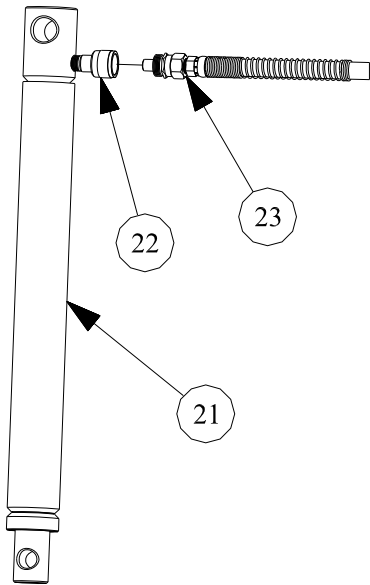

Figure 8

Any air in the cylinder [#21] must be removed from the cylinder for proper functioning of the crane.

1. Remove the protective cap and seal from the quick coupler [#22] on the cylinder [#21].
2. Connect the hydraulic hose [#23] to the quick coupler [#22] on the cylinder [#21] by inserting the male end of the hose [#23] into the quick coupler [#22] and thread the quick coupler's collar onto the hose.
3. Support the cylinder [#21] so the end with the quick coupler [#22] is higher than the rod end. Route the hose [#23] from the cylinder [#21] back to the pump so the hose [#23] is lower at the end that connects to the cylinder [#21] than at the end that connects to the pump.
4. SLOWLY extend the cylinder rod from the cylinder [#21] by closing the release knob and actuating the pump until the cylinder rod is fully extended. After the cylinder rod has been extended, open the release knob and hold the cylinder so that the quick coupler fitting is on the upper part of the cylinder and the cylinder rod is pointing down. Carefully push the rod into the cylinder until it is fully retracted. Repeat this process to ensure there is as little air as possible left in the cylinder. **WARNING!** Any operation of the cylinder while detached from the crane must be done carefully. If the cylinder is extended too quickly or is pressurized to much it poses the possibility of hitting someone, moving unexpectedly, or breaking apart and may lead to property damage, serious personal injury, and/or death.
5. Disconnect the hydraulic hose [#23] from the quick coupler [#22] once all the air has been purged from the cylinder.

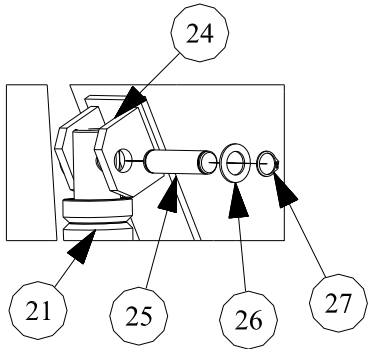

Figure 9

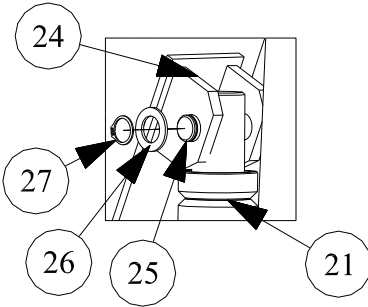

Figure 10

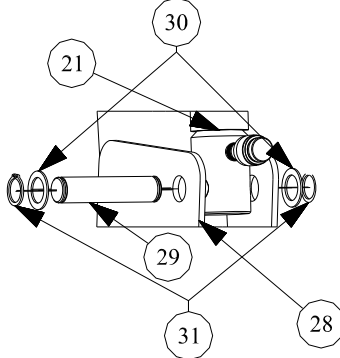

Figure 11

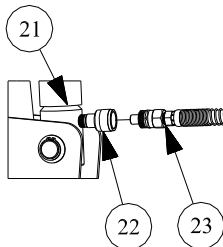

Figure 12

6. Mount the rod end of the hydraulic cylinder [#21] to the cylinder mounting bracket [#24] located on the boom by aligning the cylinder's hole with the holes in the mounting bracket and insert the 3/4" upper cylinder retaining pin [#25] as shown in Figure 9.
7. Place a 3/4" washer [#26] onto the retaining pin [#25] and then snap a 3/4" retaining ring [#27] into the groove on the retaining pin [#25] and push the retaining pin [#25] until the retaining ring [#27] stops its travel.
8. On the opposite side of the retaining pin [#25], place the other 3/4" washer [#26] onto the retaining pin [#25] and then snap the other 3/4" retaining ring [#27] into the groove on the retaining pin [#25] as shown in Figure 10.
9. Align the hole on the quick coupler end of the cylinder [#21] with the holes of the cylinder mounting plates [#28], lifting the boom if necessary and making sure that the hydraulic hose quick coupler fitting is pointing away from the frame of the crane as shown in Figure 11. Insert the 1" lower cylinder retaining pin [#29] into the aligned holes and adjust so that an approximately equal length protrudes from each of the mounting plates. Place a 1" washer [#30] onto each side of the retaining pin and snap a 1" retaining ring [#31] into each of the grooves in the retaining pin.
10. Insert the hydraulic hose [#23] into the cylinder's quick coupler [#22] and thread the quick coupler's collar onto the hose.

Operating Instructions

This section discusses the appropriate and safe methods for using the Shop Cranes. **Note:** *It may be necessary for some or all of the following steps to be completed using two people.*

⚠ WARNING

Using the crane requires several steps that must be followed each and every time the crane is used:

1. Adjusting the Boom
2. Adjusting the Legs
3. Positioning the Crane
4. Securing the Load
5. Adjusting Load Height
6. Moving the Load
7. Folding Legs for Storage

Each of these steps is discussed in detail in the following sections. Failure to follow all of these instructions can lead to serious injury and/or death.

1. Adjusting the Boom

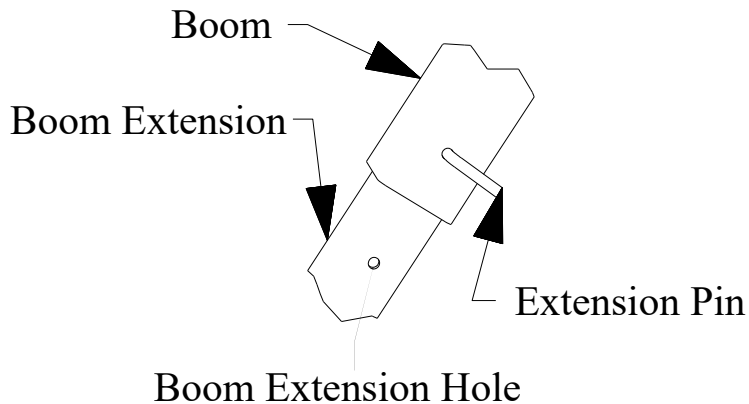

Figure 13

1. To adjust the boom's extension length between the crane's three boom positions, the extension pin must first be removed from the boom.
2. After the extension pin is removed, slide the boom extension in or out of the boom until the desired position is reached.
3. The extension pin must then be inserted into the boom extension holes that are in line with the boom's pin holes before the crane is operated further. The capacity of the crane in each of the extension positions must be noted prior to attaching a load and that capacity must not be exceeded.

WARNING! *The crane's extension pin must be in place before operating the crane and the capacity for that extension position must not be exceeded. Operating the crane without the extension pin or with a load that exceeds capacity may result in equipment failure leading to property damage, serious personal injury, and/or death.*

2. Adjusting the Legs

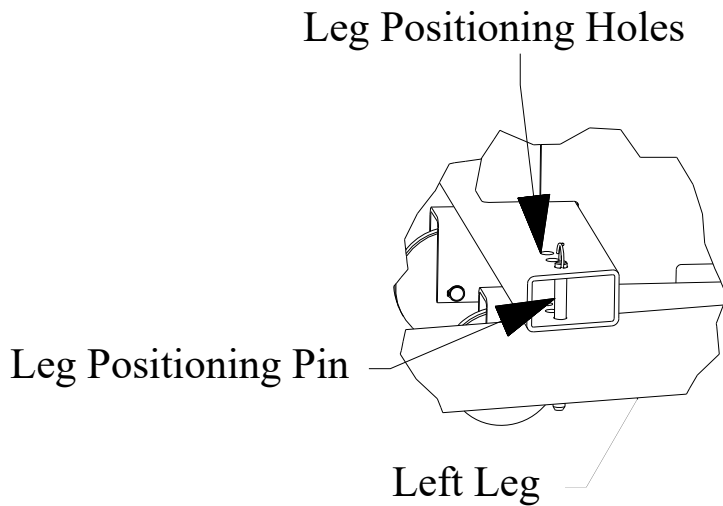

Figure 14

1. If not already lowered, the crane's legs must both be lowered so the casters rest on the floor prior to using the crane to lift a load. **WARNING!** *Lifting a load with the crane while either of the legs is in the folded position could cause instability of the crane. The crane may tip or fall over causing property damage, serious personal injury, and/or death.*
2. To adjust the spread of the crane's legs, the leg positioning pin must be removed from each leg that is to be repositioned.
3. Each leg can then be swiveled into the desired position of the three possible positions. The leg positioning pin from each repositioned leg must then be inserted into the leg positioning holes and through that leg's pin holes. **WARNING!** *Failure to properly insert the leg positioning pin into each leg can cause instability in the crane and may lead to property damage, serious personal injury, and/or death.*

3. Positioning the Crane

After the crane has been properly adjusted, it can be moved in to position to secure the intended load. The crane must be able to freely roll into position and all potential obstacles must be carefully negotiated or moved. When positioning the crane, always consider the way in which the load will be secured to the crane. The crane's chain, or other adequate load capturing device that meets or exceeds the capacity of the crane in its given position, must be located directly over the intended load before attempting to secure the load. It is important to the safety of the crane operator and other personnel that the path of the crane is carefully planned, both before and after securing the load. **WARNING!** *Contacting any obstacle, including overhead obstacles, with the crane can make the crane jump or shift which can cause the load to swing or rotate dangerously and may lead to property damage, serious personal injury, and/or death.*

4. Securing the Load

Once the shop crane has been positioned, the load must be secured utilizing an adequate capturing device, such as a load leveler, chain, or sling, capable of sustaining the load. The load must be secured by using attachment points that are adequate for holding the weight of the load and allow the load to be lifted without shifting or rotating. Ensure that the hook and chain assembly or other adequate load capturing device is directly above the load to be raised. Pay careful attention to how the load will react when raised. If the center

of gravity of the load is not directly under the crane's capturing device, or the load is awkwardly captured, the load and crane may swing or rotate dangerously. **WARNING!** *Ensure that the load is properly secured before attempting to lift or move it. If the load is improperly secured it can unexpectedly fall, swing, or rotate dangerously which may lead to property damage, serious personal injury, and/or death.*

5. Adjusting Load Height

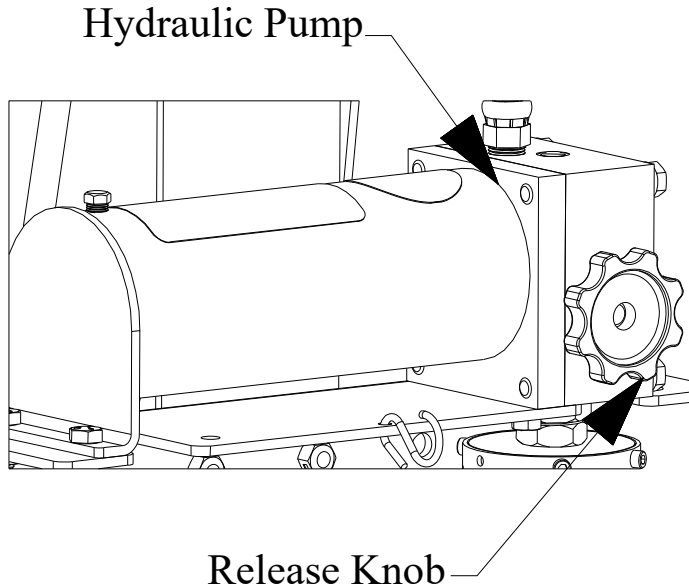

Figure 15

The hydraulic pump is used to adjust the height of the load.

1. To raise the load, the release knob on the pump must be closed by turning the knob clockwise until it is finger tight.
2. The pump can then be actuated by working the handle on the manual pump or activating the air valve on the air hydraulic pump, depending on which type of pump is installed.
3. While the pump is actuated, the cylinder will extend raising the boom and load.
4. To lower the load, the release knob must be opened by SLOWLY turning the knob counter-clockwise. This will lead to retraction of the cylinder and lowering of the load.
5. Once the load is at the desired height, the release knob must be closed in order to keep the load at that height. **WARNING!** *Lowering or stopping the load too quickly can cause the load to swing or rotate dangerously and may result in property damage, serious personal injury, and/or death. This crane is not intended for overhead lifting. Do not allow the crane's load or boom to be above any body part. If the load were to fall, it would cause serious personal injury or death.*

6. Moving the Load

Before and while SLOWLY moving the crane, pay close attention to the crane's immediate surroundings. Ensure that all obstacles are moved from the crane's path and do not neglect to consider the boom's overhead path as well as the path that the legs will follow on the floor. Before moving the crane and load, position the load at its lowest possible height. Once any height restricting obstacles (i.e. engine compartment) have been cleared by the load, stop and reposition the load to its then current lowest possible height and continue doing

so until all obstacles have been cleared. After the load has been successfully moved to the desired location, it should be lowered on to or attached to a surface or device (i.e. engine stand) that will adequately support the load. **WARNING!** *The crane is designed for lifting, moving, and lowering a load and is not intended to hold or support a load for extended periods of time.* Moving or stopping the crane too quickly or recklessly can cause the load to swing or rotate dangerously and may result in property damage, serious personal injury, and/or death.

7. Folding Legs for Storage

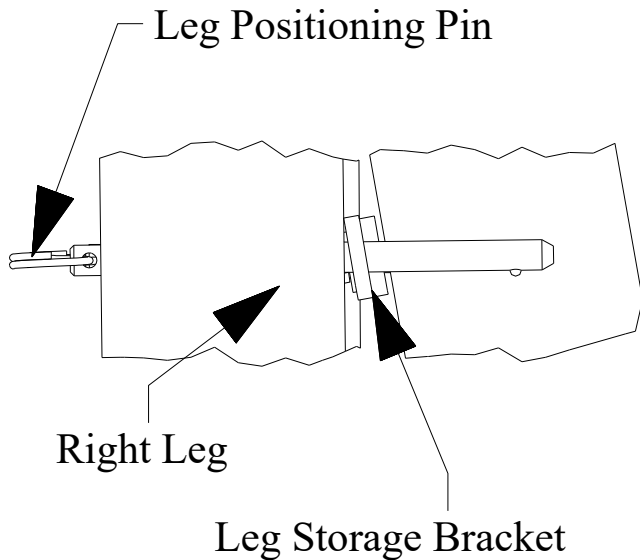

Figure 16

Before folding the legs for storage the following must be checked.

- The load must be removed from the crane.
- The boom extension must be positioned in the shortest position.
- The boom must be fully lowered.

WARNING! *Failure to check all of the conditions listed above before folding the legs may cause the crane to tip forward as the legs are folded resulting in property damage, personal injury, and/or death.*

After all of these conditions have been met, the crane's legs can be folded up for storage by completing the steps below.

1. Remove the leg positioning pin from each of the crane's legs.
 2. Rotate the legs outward until they clear the crane's frame.
 3. Separately lift each of the legs and rotate them until they are vertical. Insert the leg positioning pin into the leg and then through the leg storage bracket as shown in Figure 16. Ensure that the pin has secured the leg onto the leg storage bracket and that the leg positioning pin is fully inserted into the leg.
- WARNING!** *Failing to properly secure the legs can cause the legs to fall unexpectedly and may result in property damage, serious personal injury, and/or death.*

Maintenance and Lubrication Instructions

WARNING

All inspection and maintenance procedures must be performed *after* the equipment has been removed from service. Failure to heed this warning may result in personal injury and / or property damage.

All maintenance and lubrication procedures must be performed every two months. To properly maintain the crane, perform the following procedures:

- Lightly oil all pins to prevent corrosion. The pins that must be oiled are the leg positioning pins, boom extension pin, and the cylinder retaining pins.
- Lightly oil the chain, hook, and any appropriate part of other load capturing devices to prevent corrosion.
- If equipped with an air pump, add a few drops of air tool oil to the air line and operate the pump. This will help lubricate the air piston and prevent moisture in the air line from corroding the inside of the air motor.
- Inspect the condition of all decals on the crane. They should be legible and easy to read. If they become hard to read, clean with a mild soap and water solution or replace immediately.

Structural Inspection

WARNING

Equipment must be removed from service and inspected for damage immediately if subjected to an abnormal shock or load. Failure to heed this warning may result in personal injury and / or property damage.

NOTICE

The owner must inspect, or appoint a knowledgeable person to inspect the crane for signs of damage, corrosion, excessive wear, oil leaks, air leaks (if equipped with air pump), abnormal operation, or any other potential problem.

NEVER use a crane that appears to be damaged in any way. If any irregularities or problems are detected during an inspection, the crane must be removed from service immediately and repaired.

Contact the manufacturer using the contact information on the back cover of this manual to report any problems.

Use the following procedures to inspect the crane for wear or damage:

Inspect Crane Frame, Chain, and Hook

- Check the crane for corrosion, cracked welds, or any other damage such as cracks, chips, dents, marring, or other deformation. If any corrosion or damage is discovered, immediately remove the crane from service and contact the manufacturer using the contact information found on the back cover of this manual.
- Check the crane's chain and hook or other load capturing device for corrosion or any damage such as cracks, chips, dents, marring, or other deformation. Keep all load capturing devices of the crane in good working order. If they are damaged or are excessively corroded, replace. Use only devices supplied by the manufacturer of the crane.

Inspect All Hydraulic Components

- Inspect the hydraulic hose and fittings for any signs of wear, damage, or oil leaks. **NEVER** use a damaged hose or fittings.
- **WARNING!** *NEVER bend the hydraulic hose through less than a 5 inch radius.*
- **DANGER!** *Keep the hydraulic system away from flames and heat. NEVER impact the hydraulic system in any way.*
- Make sure the release knob operates properly.
- Inspect the cylinder and cylinder rod for any signs of wear, damage, or oil leaks. The cylinder rod should be straight without any gouges, scratches, or marks. The cylinder must be free of dents, gouges, or other damage. **NEVER** use a cylinder that is damaged in any way.

Inspect All Air Components (If equipped with air pump only)

- **WARNING!** *This press is designed to operate with air pressure of 95 psi to 200 psi. NEVER exceed this rating.*
- Check the air line and fittings for signs of wear, damage, or leaks. Replace the air line if any damage is found.
- Make sure that the air valve is working properly. To prevent the risk of serious injury, the boom must stop immediately when the air valve is released.

Inspect Boom Extension Pin and Leg Positioning Pins

- Inspect the boom extension pin and leg positioning pins for any signs of damage. The pins must not be bent, cracked, corroded, or excessively worn. **WARNING! NEVER use pins that show any sign of damage. Using damaged pins can cause the pins to fail resulting in a sudden drop of the load and/or instability of the crane causing personal injury and/or property damage.**

If the crane is overloaded, take the crane out of service immediately and inspect. Replace any damaged components by contacting the manufacturer using the contact information on the back cover of this manual. **ONLY** use repair parts supplied by the manufacturer to repair this crane. **NEVER** use spare parts from other sources; they may not be designed to be used on this crane or rated at the same capacity.

Troubleshooting

This section contains a list of problems that may be encountered and their solutions. If the provided solutions fail to correct the problem, contact the manufacturer using the contact information on the back cover of this manual.

PROBLEM

CAUSE / SOLUTION

Air motor won't run (If equipped with air pump)	Airline leaks, locate and correct leaks. Air piston sticking or stuck, add oil to air inlet to lubricate piston. Inadequate air pressure, requires at least 95 psi to lift rated load.
Cylinder will not extend.....	Check level of oil in reservoir. If necessary add a high-grade hydraulic fluid equivalent to Conoco MV22 Super Hydraulic Oil. Refer to the "Hydraulic Pump Installation" section for instructions on adding oil.
Cylinder rod does not extend/retract smoothly.....	Air in hydraulic cylinder. Follow the steps in the "Hydraulic Cylinder Installation" section to purge the air from the cylinder. The cylinder will need to be removed from the crane, purged, and then reinstalled as described in the "Hydraulic Cylinder Installation" section to properly remove the air.

Model CLHMSC-220/440

P.N. 670-90557