

# **CL Challenger Lifts**

## **Installation, Operation & Maintenance Manual** ***Dual Scissor Lift***



### **MODEL DX77**

**7,700 LBS. CAPACITY**  
**3,850 LBS. PER PAD**

2311 South Park Rd Louisville, Kentucky 40219

Email: [sales@challengerlifts.com](mailto:sales@challengerlifts.com) Web site: [www.challengerlifts.com](http://www.challengerlifts.com)

**Office 800-648-5438 / 502-625-0700 Fax 502-587-1933**

**IMPORTANT: READ THIS MANUAL COMPLETELY BEFORE  
INSTALLING or OPERATING LIFT**

## GENERAL SPECIFICATIONS

See Figure 1	DX77R (Flush Mount)	DX77 (Surface Mount)	DX77 (Surface Mount) For Wide Electric Car
<b>A</b> *Outside to Outside of Platform	69 1/2"		83.8"
<b>B</b> *Overall Width	-	82"	95 1/2"
<b>C</b> Distance between Platforms	21" - 27"		36.8"
<b>D</b> Platform Width	24 1/2"		
<b>E</b> Distance to Controls	Refer to Fig. 2		
<b>F</b> Platform Length	59"		
<b>G</b> Ramp Length	11 3/4"		
<b>H</b> Overall Length	83 1/4"		
<b>J</b> Raise Height	70"	74 1/2"	
<b>K</b> Lowered Height	-	4 1/2"	
** Max Capacity at 7" Net Rise	7,700 lbs [3,500 kg]		
** Max Capacity at 3" Net Rise	3,850 lbs [1,750 kg]		
*** Lifting Time	43 Seconds		
Motor	2HP, Single Phase, 60Hz, 208/220		
Air Supply Required	90-120 psi Clean and Dry		

\*Based on 21" for Dimension "C" but can be adjusted accordingly.

\*\* Lift capacity ratings are based on loads equally distributed.

\*\*\* Lifting and lowering speeds may vary depending on the weight of the vehicle.

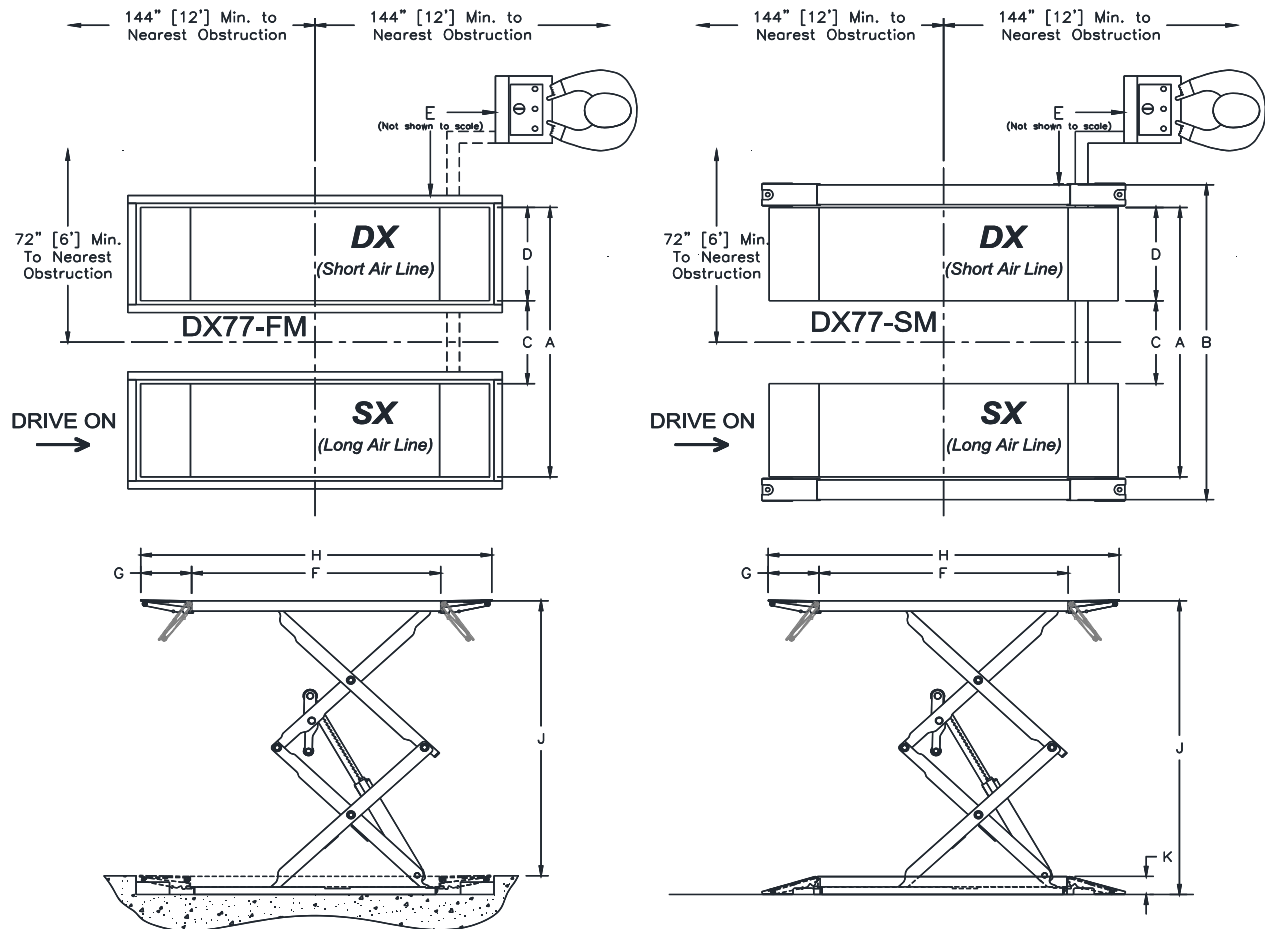

Fig. 1 - General Specifications

## VERTICAL CLEARANCE

Check the height of the area where the lift is to be installed. Clearance should be calculated based on the full raised height of the lift.



**WARNING** Failure by purchaser to provide adequate clearance could result in unsatisfactory lift performance, property damage, or personal injury.

## FLOORING

Be certain you have the proper concrete floor to properly handle the loaded lift. Floor should be in generally good condition with no large cracks, spalling or deterioration.

**Minimum requirements for concrete are 4 inches minimum depth, with steel reinforcement, 3500 psi, cured for 28 days per local commercial practice.** Floor should be level within 3/8 inch over the installation area. No anchors should be installed within 8 inches of any crack, edge, or expansion joint. If these conditions cannot be met, a pad may be poured to accommodate the lift.

Check with local building inspectors and/or permits office for any special instructions or approvals required for your installation.



**WARNING** Failure by purchaser to provide the recommended mounting surface could result in unsatisfactory lift performance, property damage, or personal injury.

## LOCATION

This lift has been evaluated for indoor use only with an operating ambient temp. range of 5 – 40°C (41– 104°F)

## ELECTRICAL REQUIREMENTS

For lift installation and operation, it is necessary to have a dedicated circuit with circuit breaker or time delay fuse. Refer to wiring diagram for circuit sizing.

## SAFETY NOTICES AND DECALS

For your safety, and the safety of others, read and understand all of the safety notices and decals included here.

**READ ENTIRE MANUAL BEFORE ASSEMBLING, INSTALLING, OPERATING, OR SERVICING THIS EQUIPMENT.**

**PROPER MAINTENANCE AND INSPECTION IS NECESSARY FOR SAFE OPERATION.**

**DO NOT OPERATE A DAMAGED LIFT.**

Safety decals similar to those shown here are found on a properly installed lift. Be sure that all safety decals have been attached to the control console of the lift. Verify that all authorized operators know the location of these decals and fully understand their meaning. Replace worn, faded, or damaged decals promptly.



**WARNING** Do not attempt to raise a vehicle on the lift until the lift has been correctly installed

and adjusted as described in this manual.

### SAFETY INSTRUCTIONS

If attachments, accessories or configuration modifying components that are located in the load path, affect operation of the lift, affect the lift electrical listing or affect intended vehicle accommodation are used on this lift and, if they are not certified for use on this lift, then the certification of this lift shall become null and void. Contact the participant for information pertaining to certified attachments, accessories or configuration modifying components.

www.autolift.org ©2007 by ALL, Inc. ALI / WLSIA01

### SAFETY WARNING LABELS FOR HINGED FRAME ENGAGING LIFTS

Lift Owner/User Responsibilities:

- A. This Safety Warning placard **SHALL** be displayed in a conspicuous location in the lift area.
- B. Use one of the mounting arrangements illustrated on back of this placard.
- C. These Safety Warning labels supplement other documents supplied with the lift.
- D. Be certain all lift operators read and understand these labels, operating instructions and other safety related information supplied with the lift.

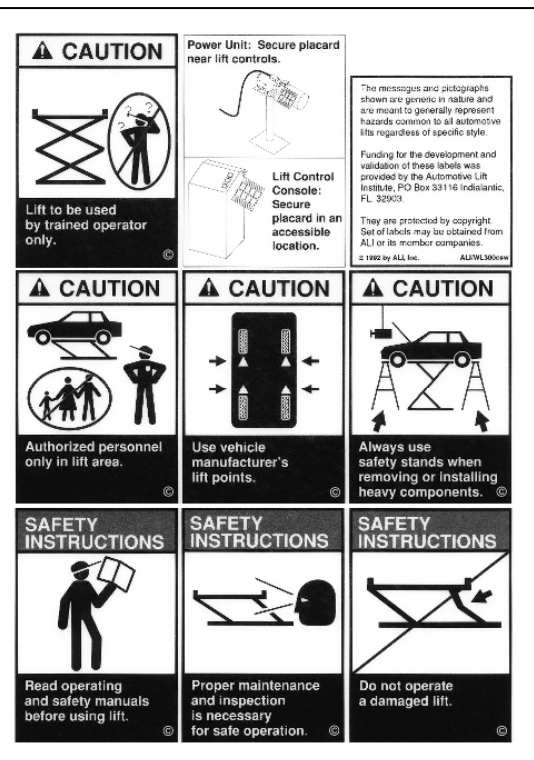

## RECEIVING

The shipment should be thoroughly inspected as soon as it is received. The signed bill of lading is acknowledgement by the carrier of receipt in good condition of shipment covered by our invoice.

If any of the goods called for on this bill of lading are shorted or damaged, do not accept them until the carrier makes a notation on the freight bill of the shorted or damaged goods. Do this for your own protection.

NOTIFY **Challenger Lifts** AT ONCE if any hidden loss or damage is discovered after receipt.

IT IS DIFFICULT TO COLLECT FOR LOSS OR DAMAGE AFTER YOU HAVE GIVEN THE CARRIER A CLEAR RECEIPT.

File your claim with **Challenger Lifts** promptly. Support your claim with copies of the bill of lading, freight bill, and photographs, if available.

**ACCEPTED OILS** – Do not use oils with detergents  
*Hydraulic fluid is not provided with the lift shipment.*

-10 wt. anti-foam, anti-rust hydraulic / biodegradable oil

-Dexron III ATF

## Edition of Standards Referenced

Where any ANSI standard is referenced within this manual, the most recent edition approved by the American National Standards Institute, Inc. shall apply.

## INSTALLATION

**IMPORTANT:** Always wear safety glasses while installing lift.

### TOOLS (MINIMUM REQUIRED)

- a. Tape measure, 16ft
- b. Chalk line
- c. 4ft level
- d. 10" adjustable wrench
- e. Standard open end wrenches 9/16", 3/4"
- f. Needle nose pliers
- g. Hammer drill with 1/2" diameter carbide tipped bits
- h. 2lb hammer
- i. Torque wrench: 40-foot pounds minimum with 3/4" socket
- j. Allen Wrench 8mm
- k. Long oil funnel

## SURFACE MOUNT & FLUSH MOUNT LAYOUT

- 1) Layout the service bay according to the architect's plans or owners' instructions (*see Fig. 1*). **Failure to install in this orientation can result in personal and property damage.** Be certain that the proper conditions exist, see page 3.

**NOTE: The correct orientation of the platforms (DX & SX) is critical for proper layout of the lift. The SX pad contains the longer air line which is located under the front pivoting ramp.**

- 2) See **Fig. 2** for control console location. Relocating the control console further away than the standard distance will require the installer to provide suitable hydraulic hoses and air line. Additional hose covers will also be needed if installing lift in surface mount configuration. Hydraulic hoses should be 1/4" minimum ID with a minimum working pressure of 3000 psi and a minimum burst pressure of 12,000 psi with #6 JIC Swivel Female fittings. The air line for the locks requires Ø6mm OD x 1mm wall poly tubing. **NOTE: Extend both hydraulic hoses the same length and do not extend the hoses more than 21 feet [252 in].**
- 3) Relocating the control console from DX to SX side will require moving the green hose blocks at the base of the unit under the ramp to direct the hoses to the new side.
- 4) If the platform spacing is more than 27" wide such as for wide electric vehicles, an extension for the hydraulic hose and airline may be required to locate the control box in the desired location. See Step #2 for hose and airline specs. For Wide Electric Vehicles, please refer to DX77-SUP-T provided with the optional hose cover (10354-4).

### FLUSH MOUNT PIT REQUIREMENTS

- 5) **PRIOR TO POURING CONCRETE**, installer will need the Flush Mount Kit (Part# DX77-FM). Please contact the phone number listed on the front cover of the manual for additional assistance. The kit contains frame components with concrete ties that will need to be in place during concrete pour. See parts breakdown in the back of the manual for included components. Temporary pit forms are not provided and will be the responsibility of the installer.
- 6) For flush mount pit specifications, see **Fig. 3**.

**CONTROL CONSOLE LAYOUT**

7) Place Control Console as shown in **Fig. 2** for surface mount or flush mount applications. Operator should be in a position to notice any misalignment of lifting pads or vehicle during operation. Challenger Lifts does not recommend placing the console in a different location or orientation and doing so would be the responsibility of the installer and/or end user.

***IMPORTANT: Control console should always be orientated so operator is facing the direction of the lift when operating the lift.***

8) If lift will be a flush mount application, the total run length of the pipe chase from pit to bottom rear of the control console should not exceed 72". The standard hose will only allow 72".

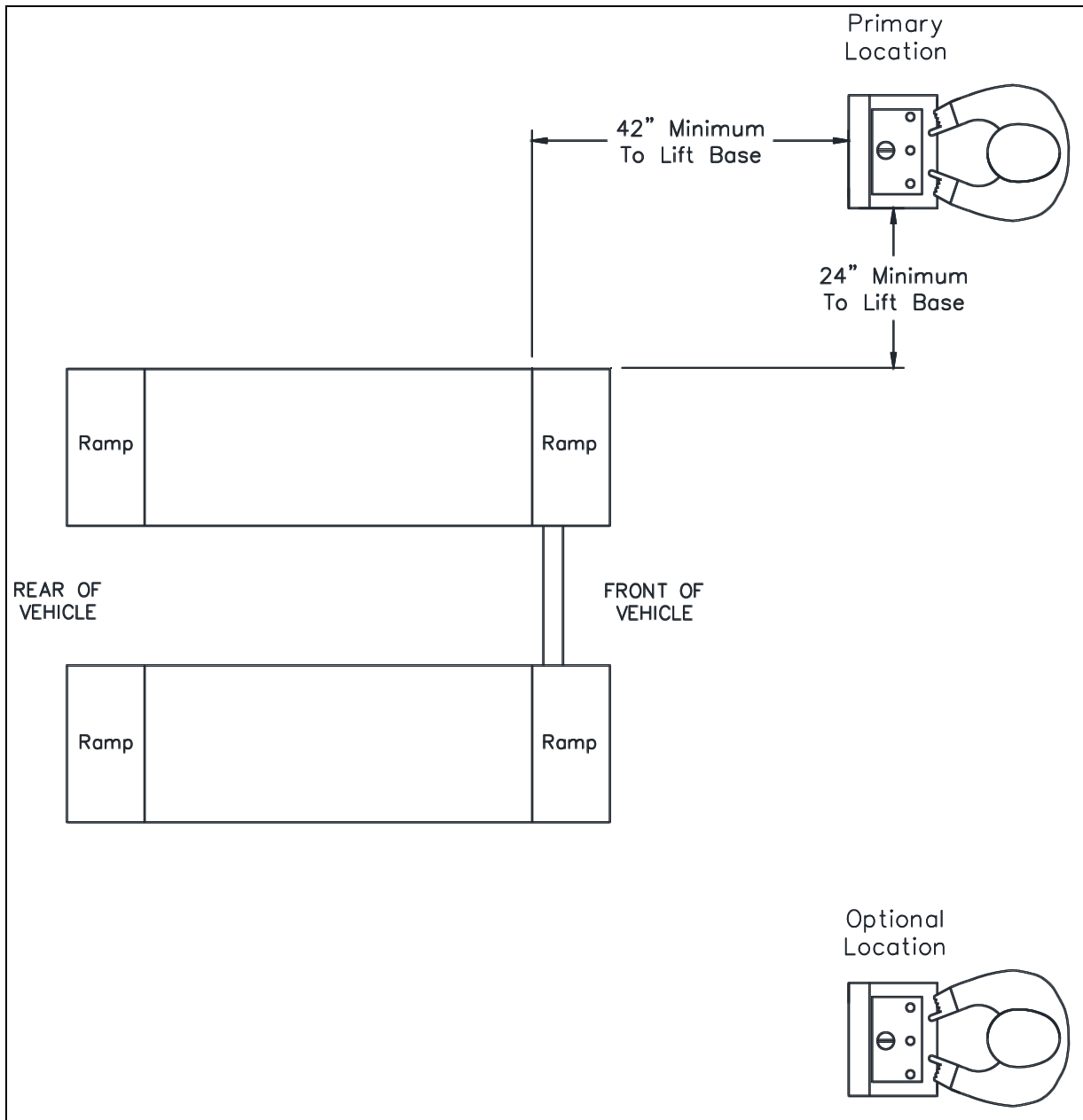

**Fig. 2 – Control Console Placement**

**FOR FLUSH MOUNT ONLY**

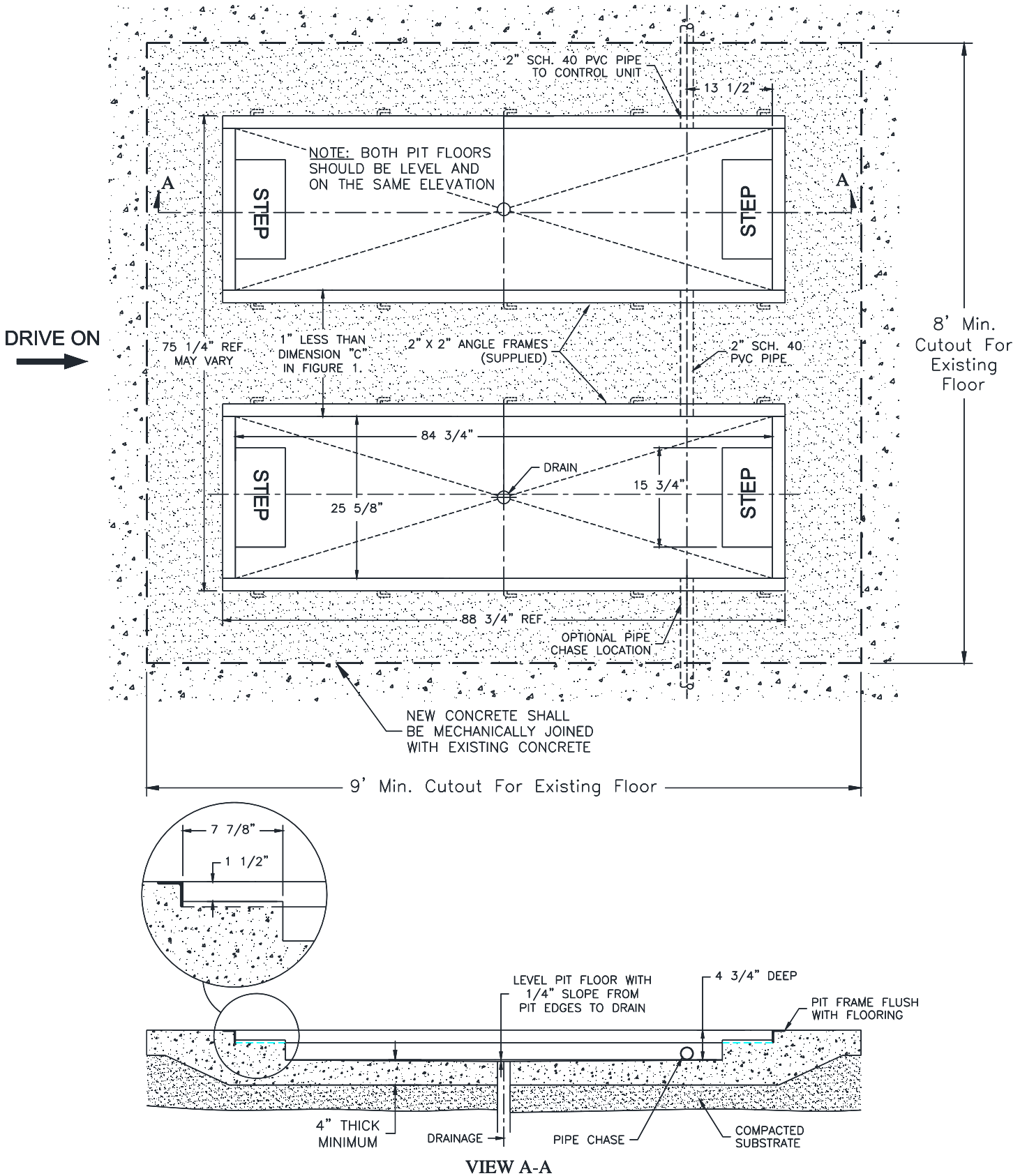

**Fig. 3 – Flush Mount Pit Specifications**

### ELECTRICAL CONNECTION

- 9) Connect Power Unit to suitable electrical source as shown in Fig. 11.

Each lift shall have a dedicated circuit with a 30 Amp double-pole breaker or time delay fuse.

Wiring must comply with all local electrical codes.

**NOTE:** All three switches are “momentary”, so the function only remains energized while the button is depressed.

- 10) Use an 8mm Allen wrench to remove the button/control cover on the control unit.
- 11) Connect the electrical supply to the contactor (L1 & L2) on the back side of the cover, Fig. 4. Connect the ground wire to the console below the cover.

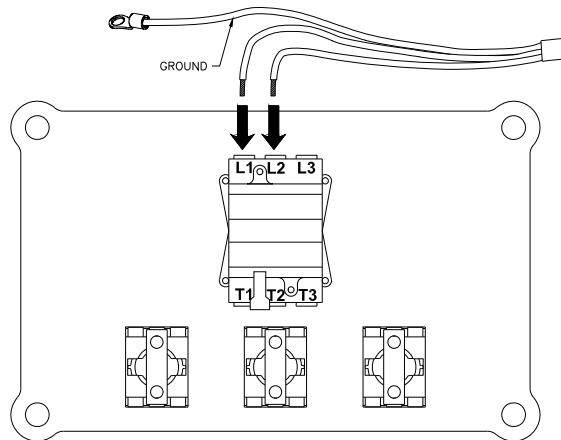

Fig. 4 – Power Supply Connection

### HYDRAULICS / AIR

- 12) Remove the front cover to the control unit by lifting the bottom of the door up and pulling towards you, and route both hydraulic lines from the pads thru the bottom rear of the control unit.
- 13) Connect the hydraulic lines to the block connections inside the control unit, Fig. 5.

**NOTE:** The hydraulic lines from the lift platforms can connect to either port.

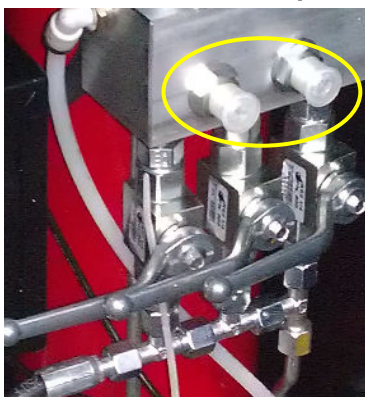

Fig. 5 – Hydraulic Connection

- 14) Inside the control console locate the (2) Ø4mm air lines. One will lead to the pads, the other air line will have a 1/8 NPT female fitting to connect the inline air filter and hose barb (from the hardware box) to, Fig. 6.

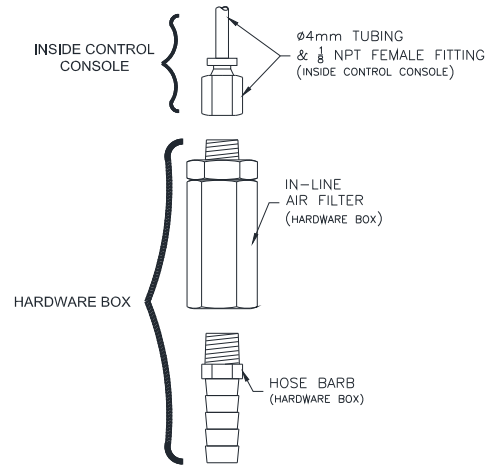

Fig. 6 – Air Connection

### ELECTRICAL TESTING

- 15) After wiring is complete, test the function of the three control buttons with the main disconnect switch in the ON position:
  - a) Pressing the “UP” button should energize the power unit motor to raise the lift.
  - b) Pressing the “LOCK RELEASE” button should energize the air valve inside the Control Console to allow the shop supply air to energize the lock release air cylinder.
  - c) Pressing the “DOWN” button should energize the power unit lowering valve to lower the lift into the nearest lock.

### BLEEDING/SYNCHRONIZATION PROCEDURE

- 16) Fill the reservoir with 4 gallons of the proper oil, see **ACCEPTED OILS** listed on page 4.
- 17) Turn power on and ensure the disconnect switch is in the "ON" position and proceed with the following steps. DO NOT skip any step.
  - A. Ensure all 3 valves are closed, **Fig. 7**.
  - B. Press **UP** until both pads stop moving. \*Note 1
  - C. **OPEN** all 3 valves.
  - D. Press **UP** until both pads stop moving.
  - E. Bleed air from each pad cylinder, **Fig. 8**.
  - F. If pads lower into a lock position, press UP.
  - G. Continue bleeding until oil begins to escape.
  - H. Press UP until both pads stop moving.
  - I. **CLOSE** all 3 valves.
  - J. Press **LOCK RELEASE & DOWN**. \*Notes 2,3
  - K. Repeat entire procedure. \*Note 4

**Note 1:** If pads do not rise after pressing **UP** for 30 seconds, continue to step "C" of procedure.

**Note 2:** If pads stop moving while lowering during the bleeding process, **OPEN** all 3 valves and continue lowering. Once both pads are completely lowered, **CLOSE** all 3 valves and repeat the entire bleeding procedure.

**Note 3:** With pads completely lowered, add oil to fill reservoir.

**Note 4:** The bleeding procedure should be performed at least 3 times and repeated until both pads are synchronized thru the complete raising and lowering of the pads and no air comes out of either bleed screw.

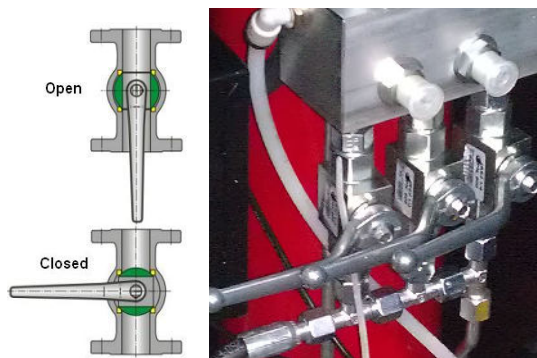

**Fig. 7 – Valves (Hoses not shown)**



**Fig. 8 – Bleed Screw**

### LIFT LEVELING/ANCHORING

- 18) The anchor bolts must be installed at least 6" from any crack, edge or expansion joint.
- 19) Use a concrete hammer drill with a 1/2-inch carbide bit. Tip diameter should conform to ANSI Standard B212.15 (.520 to .530). Do not use excessively worn bits or bits which have been incorrectly sharpened. A core bit may be necessary if an obstruction is encountered. **Never substitute with a shorter anchor.**
- 20) Recheck the layout dimensions, **Fig. 1**. Raise the lift and use the (4) holes in the base of each pad as a template. Drill through the floor if possible.
- 21) Vacuum dust from the hole for proper holding power.
- 22) Ensure the lift is level. Use the provided shims to level the lift at anchor holes. DO NOT shim more than 1/2" at any given point. Use a level no less than 24" in length. Additional shims or grout should be placed under base side channels where the lower slide blocks travel and under pivot blocks in the front to prevent bending of the base as shown below. Grout should meet or exceed minimum required properties of concrete.

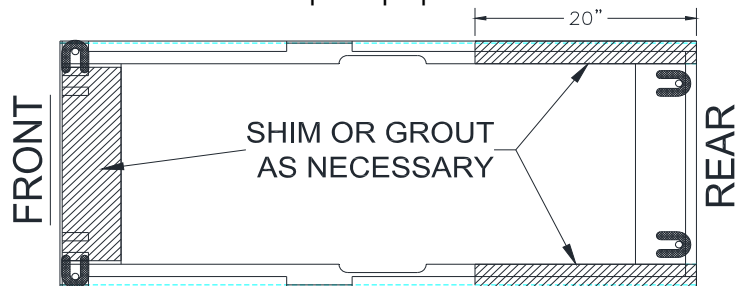

**Fig. 9 - Leveling**

- 23) Assemble washer and nut to anchor with nut just below impact section of bolt. Drive anchor into hole until nut and washer contact base.
- 24) Tighten anchors and recheck level. Re-shim if necessary. Torque to 40-foot pounds to set anchors.
- 25) **DX77 SURFACE MOUNT** – Per **Fig. 1**, layout the drive over ramps with approx. 3/4" gap between the platform and the ramp. Use the hammer drill with 1/2" carbide bit and use the hole in the ends of each ramp as a template. Torque anchors to 40-foot pounds to set.
- 26) Use the provided 20" sections of hose cover to protect the hose and air line for the surface mount application. If the console has been located further away than the standard 60", additional hose cover sections may be needed.
- 27) Drill Ø1/4" holes using the hose covers as a template and secure the covers to the floor with the provided 1/4" drive anchors. Repeat the process for the control console.



**OWNER/OPERATOR CHECKLIST**

- 28) Demonstrate the operation of the lift to the owner/operator/employer using a typical vehicle and review correct and safe lifting procedures using the **Lifting It Right** booklet as a guide.
- 29) Return all provided literature (including this manual) to the literature pack envelope and deliver the envelope to the owner/operator/employer.
- 30) Complete the online warranty registration (refer to the included warranty statement).

**SYNCHRONIZATION**

- 31) It may be necessary to re-synchronize the hydraulic system occasionally.
- 32) With the lift unloaded open the door to the console by pushing up and pulling out on the bottom.
- 33) Repeat the bleeding procedure in step # 17 to re-synchronize the lift.

Model DX77  
Installation, Operation and Maintenance

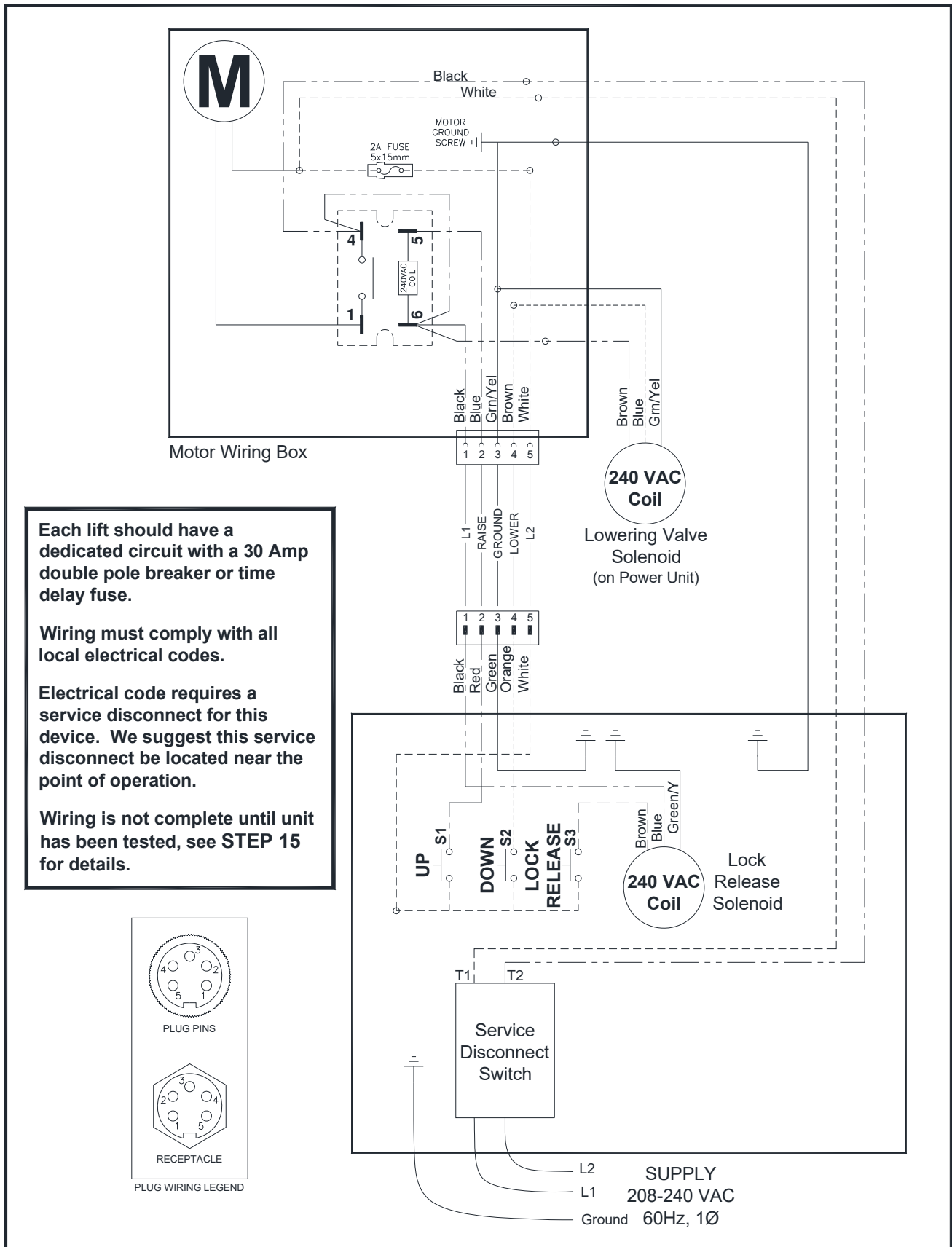

Fig. 11 – Electrical Wiring Diagram

This product is furnished with graphic safety warning labels, which are reproduced on page 3 of these instructions. Do not remove or deface these warning labels or allow them to be removed or defaced. For your safety, and the safety of others, read and understand all of the safety notices and decals included.

#### **OWNER/EMPLOYER RESPONSIBILITIES**

This lift has been designed and constructed according to ANSI/ALI ALCTV standard. The standard applies to lift manufacturers, as well as to owners and employers. The owner/employer's responsibilities as prescribed by ANSI/ALI ALOIM, are summarized below. For exact wording refer to the actual standard provided with this manual in the literature pack.

**The Owner/Employer shall** insure that lift operators are qualified and that they are trained in the safe use and operation of the lift using the manufacturer's operating instructions; ALI/SM, *ALI Lifting it Right safety manual*; ALI/ST, *ALI Safety Tips card*; ANSI/ALI ALOIM, *American National Standard for Automotive Lifts-Safety Requirements for Operation, Inspection and Maintenance*; ALI/WL Series, *ALI Uniform Warning Label Decals/Placards*; and in case of frame engaging lifts, ALI/LP-GUIDE, *Vehicle Lifting Points/Quick Reference Guide for Frame Engaging Lifts*.

**The Owner/Employer shall** establish procedures to periodically inspect the lift in accordance with the lift manufacturer's instructions or ANSI/ALI ALOIM, *American National Standard for Automotive Lifts-Safety Requirements for Operation, Inspection and Maintenance*; and the employer shall insure that the lift inspectors are qualified and that they are adequately trained in the inspection of the lift.

**The Owner/Employer shall** establish procedures to periodically maintain the lift in accordance with the lift manufacturer's instructions or ANSI/ALIOIM, *American National Standard for Automotive Lifts-Safety Requirements for Operation, Inspection and Maintenance*; and the employer shall ensure that the lift maintenance personnel are qualified and that they are adequately trained in the maintenance of the lift.

**The Owner/Employer shall** maintain the periodic inspection and maintenance records recommended by the manufacturer or ANSI/ALI ALOIM, *American National Standard for Automotive Lifts-Safety Requirements for Operation, Inspection and Maintenance*.

**The Owner/Employer shall** display the lift manufacturer's operating instructions; ALI/SM, *ALI Lifting it Right safety manual*; ALI/ST, *ALI Safety Tips card*; ANSI/ALI ALOIM, *American National Standard for Automotive Lifts-Safety Requirements for Operation, Inspection and Maintenance*; and in the case of frame engaging lift, ALI/LP-GUIDE, *Vehicle Lifting Points/Quick Reference Guide for Frame Engaging Lifts*; in a conspicuous location in the lift area convenient to the operator.

#### **IMPORTANT SAFETY INSTRUCTIONS**

When using your garage equipment, basic safety precautions should always be followed, including the following:

1. Read all instructions.
2. Care must be taken as burns can occur from touching hot parts.
3. To reduce the risk of fire, do not operate equipment in the vicinity of open containers of flammable liquids (gasoline).
4. Keep hair, loose clothing, fingers, and all parts of body away from moving parts.
5. Use only as described in this manual. Use only manufacturer's recommended attachments.
6. ALWAYS WEAR SAFETY GLASSES. Everyday eyeglasses only have impact resistant lenses, they are not safety glasses.

**SAVE THESE INSTRUCTIONS**

## LIFTING A VEHICLE

- 1) Ensure that the lift pads are completely down and spotting blocks are clear of the drive path.
- 2) Center the vehicle over the pads in the service bay and position the vehicle's center of gravity midpoint on the pads. NOTE: the center of gravity is based on the weight distribution and is not the same as the center point of the vehicle.

**DO NOT EXCEED 3850 POUNDS PER PAD.**

**DO NOT ATTEMPT TO LIFT THE VEHICLE WITH ONLY ONE PAD, AS THIS WILL VOID THE WARRANTY**

**REFER TO THE VEHICLE MANUFACTURERS SERVICE MANUAL, TECHNICAL BULLETINS, "VEHICLE LIFTING POINTS GUIDE" (ALI/LP-GUIDE) OR OTHER PUBLICATIONS TO LOCATE THE RECOMMENDED LIFTING POINTS.**

- 3) Position the spotting blocks so all four pads contact the vehicle simultaneously.

**The vehicle should remain level during lifting.**

- 4) Raise the lift until all four wheels are off the ground by pressing the UP button. Test the stability of the vehicle by attempting to rock the vehicle. Check adapters for secure contact with vehicle lift points. If the vehicle seems unstable, lower the lift and readjust. If the vehicle is stable, raise the vehicle to a height a few inches above the desired working height.
- 5) Press the DOWN button lower into the locks. Lower the vehicle until the safety latches on both pads engage. The vehicle should remain level when both latches are engaged. If one side engages and the other continues to descend, stop lowering the vehicle, raise it several inches, and try again to engage both latches.

**Always lower lift into locks before entering the area beneath the vehicle.**

**Always use safety stands when removing or installing heavy components.**

## LOWERING A VEHICLE

- 1) Ensure that the area under the vehicle is clear of personnel and tools.
- 2) If lift is sitting in the locks, raise the lift out of the locks by pressing the UP button until the locks are clear.
- 3) Lower the vehicle by first pressing the LOCK RELEASE button, then the DOWN button. If pads do not stay level during lowering, discontinue lowering and check the lock mechanisms for proper functioning. Once lift decent noticeably slows down roughly 18" from ground, release the LOCK RELEASE button and continue lowering. Once completely lowered, remove the spotting blocks and ensure the ramps are down.

To avoid personal injury, permit only qualified personnel to perform maintenance on this equipment. Maintenance personnel should follow lockout/tagout instructions per ANSI Z244.1.

The following maintenance points are suggested as the basis of a routine maintenance program. The actual maintenance program should be tailored to the installation. See ANSI/ALI ALOIM booklet for periodic inspection checklist and maintenance log sheet.

- If lift stops short of full rise or chatters, check fluid level and bleed both cylinders per Installation Instructions.
- Replace all Safety, Warning or Caution Labels if missing or damaged (**See *Installation instructions page 3.***)

### Daily

- Keep lift components clean.
- Check for loose or broken parts.
- Check hydraulic system for fluid leaks.
- Check spotting blocks for damage or excessive wear. Replace as required with genuine Challenger Lifts parts.

### Weekly

- Clean around base.

### Monthly

- Torque concrete anchor bolts to 40 ft-lbs.
- Visually inspect concrete floor for cracks and/or spawls within 6" of base.
- Lubricate slide tracks with heavy viscous grease. (Grease channels of both pads)
- Grease all pins.
- Check synchronization of lift platforms, if it needs to be adjusted, please follow step 17.

**If any problems are encountered, contact your local service representative.**

## MAINTENANCE

Model DX77  
Installation, Operation and Maintenance

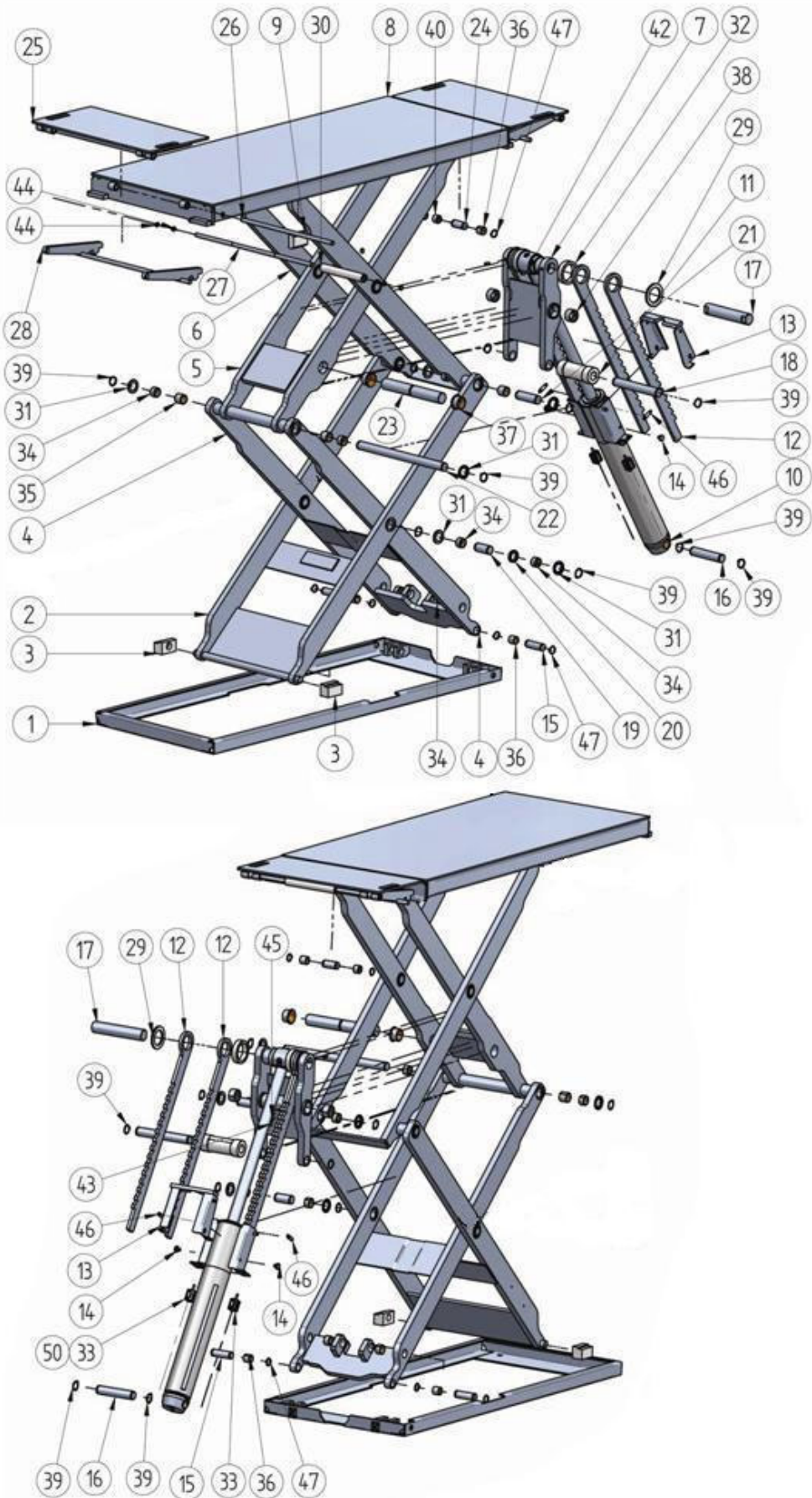

Model DX77  
Installation, Operation and Maintenance

ITEM #	PART #	QTY/LIFT	DESCRIPTION
1	3036025501	2	LOWER BASE WELD
2	3036025201	2	LOWER SCISSOR LINK WELD, SLIDE
3	3036025601	4	LOWER SLIDE BLOCK
4	3036025101	2	LOWER SCISSOR LINK WELD, PIVOT
5	3036025401	2	UPPER SCISSOR LINK WELD, PIVOT
6	3036025300	2	UPPER SCISSOR LINK WELD, SLIDE
7	3036025900	2	CYLINDER LEVER
8	3036025950	2	UPPER PLATFORM WELD
9	3036025606	4	UPPER SLIDE BLOCK
10	3036025801	2	CYLINDER, SLAVE
11	3036025611	2	CYLINDER LEVER ROLLER
12	3036025858	8	LOCK BAR
13	3036025861	2	LOCK
14	3036020191	4	LOCK BOLT
15	3036025626	4	PIN, LOWER LINK PIVOT
16	3036025616	2	PIN, CYLINDER BASE
17	3036025620	2	PIN, CYLINDER PIVOT END
18	3036025631	2	PIN, LEVER ROLLER
19	3036025635	8	PIN, CENTER PIVOT
20	3036025650	8	CENTER SPACER WASHER
21	3036025640	4	PIN, UPPER & LOWER SLIDE
22	3036025645	2	PIN, UPPER & LOWER PIVOT
23	3036025660	2	PIN, LEVER PIVOT
24	3036025666	4	PIN, UPPER SCISSOR PIVOT
25	3036025970	4	RAMP WELD
26	3036025791	4	PIN, RAMP PIVOT
27	3036025675	4	PIN, RAMP LOCK PIVOT
28	3036025795	4	RAMP LOCK LEVER
29	3036025671	4	LEVER ROLLER SPACER
30	3012151581	4	RAMP ROLLER
31	3036025686	28	SNAP RING CAPTURE
32	3036025672	4	LEVER ROLLER
33	1251041005	4	LOCK RELEASE AIR CYLINDER
34	1141070001	28	BUSHING, Ø30mm X 20mm Lg.
35	1141040000	8	BUSHING, Ø30mm X 30mm Lg.
36	1141180000	8	BUSHING, Ø25mm X 25mm Lg.
37	1141300010	4	BUSHING,
38	1141300030	4	BUSHING,
39	1071300004	36	Ø30mm RETAINING RING
40	1141200000	4	BUSHING, Ø25mm X 20mm Lg.
42	1022100203	4	M10 x 20mm Lg. BOLT
43	1022100124	2	M10 x 12mm Lg. BOLT
44	1071140003	24	Ø14mm RETAINING RING
45	1141030000	2	GREASE NIPPLE
46	3000504470	2	LOCK SPRING
47	1071250004	16	Ø25 RETAINING RING
50	1011040160	8	M4 x 16mm Lg. BOLT
51	31010419	4	AIR CYLINDER FITTING, M4 Pushlock x 5mm O-ring (NOT SHOWN)

Replace all worn or broken parts with genuine **Challenger Lifts Inc.** parts.  
Contact your local Challenger Lifts Parts Distributor for pricing and availability.  
(Call Challenger Lifts Inc. (502) 625-0700 for the Parts Distributor in your area)

Model DX77  
 Installation, Operation and Maintenance

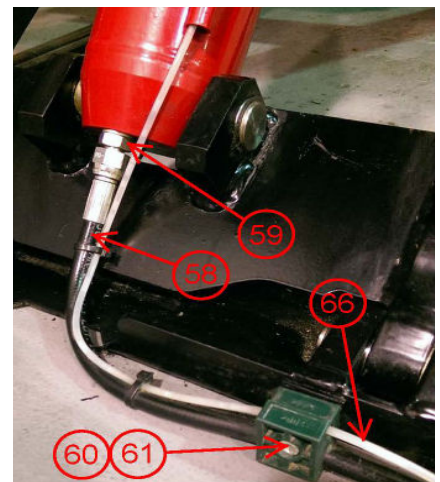
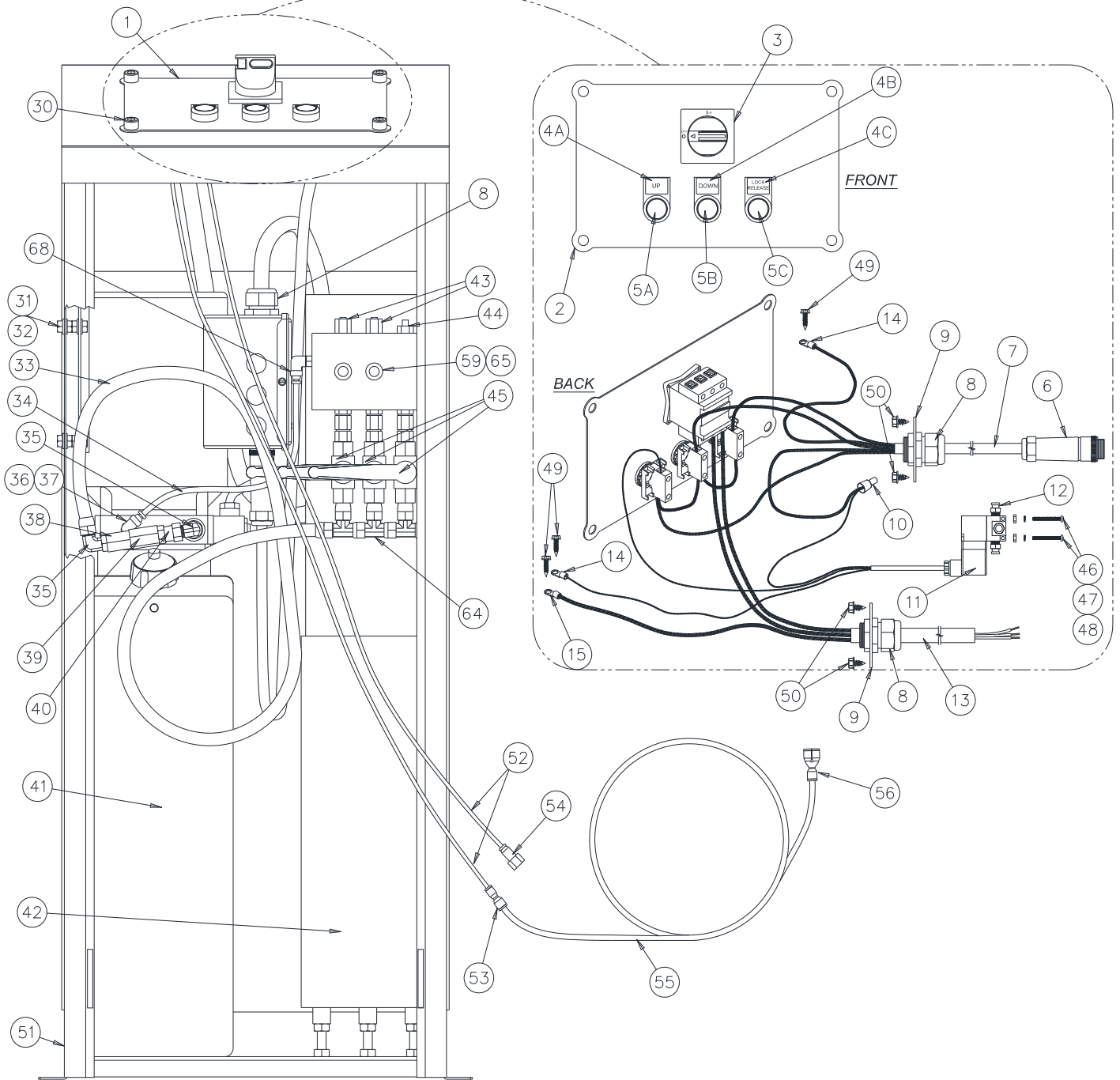

Model DX77  
Installation, Operation and Maintenance

ITEM #	PART #	QTY/LIFT	DESCRIPTION
1	DX77-200	1	CONTROL PLATE ASSEMBLY, <i>ITEMS 2-15</i>
2	DX77-100-01	1	CONTROL PLATE
3	DX77-200-01	1	SERVICE DISCONNECT SWITCH
4A	17101-5U	1	LEGEND PLATE, UP
4B	17101-5D	1	LEGEND PLATE, DOWN
4C	M22-XST-ETCH-LR	1	LEGEND PLATE, LOCK RELEASE
5A	17101-4G	1	UP PUSH BUTTON SWITCH ASSEMBLY, GREEN
5B	17101-4R	1	DOWN PUSH BUTTON SWITCH ASSEMBLY, RED
5C	17101-4B	1	LOCK RELEASE PUSH BUTTON SWITCH ASSEMBLY, BLACK
6	A1206-22	1	7/8" 5-PIN MALE STRAIGHT CONNECTOR
7	DX77-200-02	1	WIRE, 18 AWG – CONDUCTOR TYPE SOOW
8	A1205-38	2	3/4 NPT x Ø0.63" CORD GRIP
9	DX77-100-02	2	CORD GRIP PLATE
10	A1207-17-35	1	CRIP-ON WIRE CONNECTOR, 16-10 AWG
11	17110	1	AIR VALVE
12	DX77-20	2	Ø5/32" x 1/8 NPT STRAIGHT FITTING, PUSH LOCK
13	DX77-200-03	1	WIRE, 10 AWG – 3 CONDUCTOR TYPE SJOOW
14	A1206-15-16	2	RING TERMINAL, 22-18 AWG x #10 RING
15	DX77-40	1	RING TERMINAL, 12-10 AWG x #10 RING
30	CAL044	4	M10x15mm Lg. SOCKET HEAD CAPSCREW
31	A1069	3	5/16-18 x 1" Lg. HEX FLANGE HEAD CAPSCREW
32	4100237	9	5/16-18 HEX FLANGE HEAD NUT
33	DX77-HOSE-3	1	HOSE ASSEMBLY, #6 JIC FEMALE x EO8L FEMALE
34	DX77-61	1	Ø5/16" x 0.062 WALL POLY TUBING
35	16167	2	90° ELBOW, #6 SAE x #6 JIC
36	RJ6-35	1	3/8 NPT x 1/4 NPT PIPE REDUCER
37	DX77-53	1	1/4 NPT x 5/16 TUBE SWIVEL ELBOW
38	DX77-51	1	9/16 O-RING x 9/16 O-RING COUPLER
39	44011-10-170	1	EXTERNAL FLOW CONTROL
40	DX77-50	1	#6 JIC FEMALE x #6 O-RING MALE
41	AB-10714	1	POWER UNIT
42	3036025090	1	MASTER CYLINDER
43	1120160100	2	PRESSURE RELIEF VALVE, 360 bar
44	1120160100-80	1	PRESSURE RELIEF VALVE, 80 bar
45	1251120000	3	BALL VALVE
46	17108	2	#6-32 x 1-1/4 Lg. PAN HEAD SCREW
47	17109	2	#6-32 HEX NUT
48	17112	2	#6 LOCK WASHER
49	A1206-15-13	4	GROUND SCREW, 10-32 x 3/8 Lg. HEX FLANGE HEAD
50	40120	4	¼-20 x ½" Lg. Self-Tap HHCS
51	3024127080	1	CONTROL CONSOLE ENCLOSURE
52	B00901	8 ft	Ø4mm X 0.75mm WALL POLY TUBING
53	DX77-54	1	Ø6mm X Ø4mm UNION REDUCER
54	DX77-63	1	Ø5/32in X 1/8 NPT FEMALE
55	CAL011	9 ft	Ø6mm X 1mm WALL NYLON TUBING
56	DX77-55	1	Ø6mm X Ø4mm Y-UNION REDUCER
57	3024127086	1	CONSOLE DOOR (not shown)
58	DX77-75-178	2	PLATFORM HYDRAULIC HOSE
59	DX77-49	4	HYDRAULIC FITTING, #6 JIC x BSPP O-RING
60	DX77-HGB	2	HOSE GUIDE BLOCK, GREEN
61	QRJ9-41	2	M6x20 SHCS, used with item #60
62	40091	1	INLINE AIR FILTER (not shown)
63	37021	1	1/8 MNPT x 3/8 BARB FITTING (not shown)
64	DX77-66	3	HYDRAULIC TEE FITTING
65	DX77-45	1	HYDRAULIC MANIFOLD BLOCK
66	DX77-56	2	Ø4mm X 0.75mm WALL X 8' Lg. POLY TUBING
67	B37032	2	Ø4mm UNION TEE, PUSH LOCK (not shown)
68	DX77-48	1	8mm PUSHLOCK x ¼" BSPP ELBOW

Replace all worn or broken parts with genuine **Challenger Lifts Inc.** parts.  
Contact your local Challenger Lifts Parts Distributor for pricing and availability.  
(Call Challenger Lifts Inc. (502) 625-0700 for the Parts Distributor in your area)



### DX77 Surface Mount Components (Part# DX77-SM)

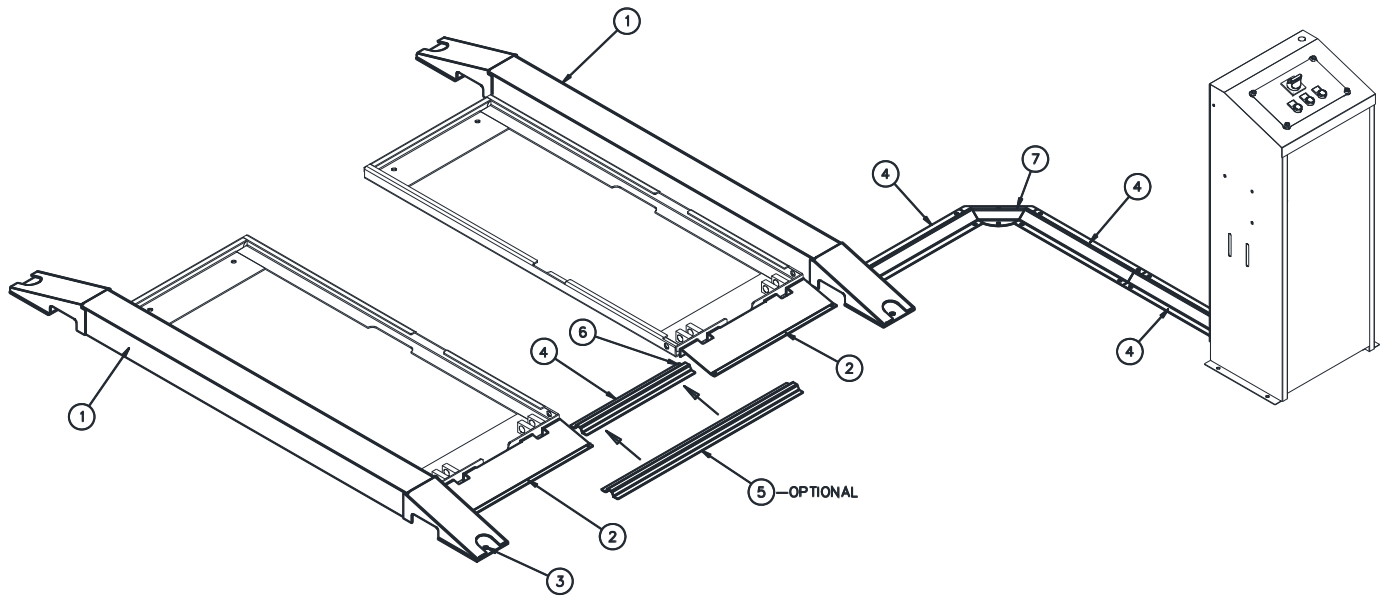

ITEM #	PART #	QTY/LIFT	DESCRIPTION
1	DX77-10	2	SURROUND WELD
2	DX77-25	2	HOSE PROTECTOR
3	68029	12	1/2 x 3-3/4" ANCHOR BOLT
4	10354-2	4	HOSE COVER
5	10354-4	1	HOSE COVER 34-1/4" (OPTIONAL)
6	484985	26	1/4 x 1-1/2" DRIVE ANCHOR
7	10354-3	1	HOSE COVER 90°

### DX77 Flush Mount Components (Part# DX77-FM)

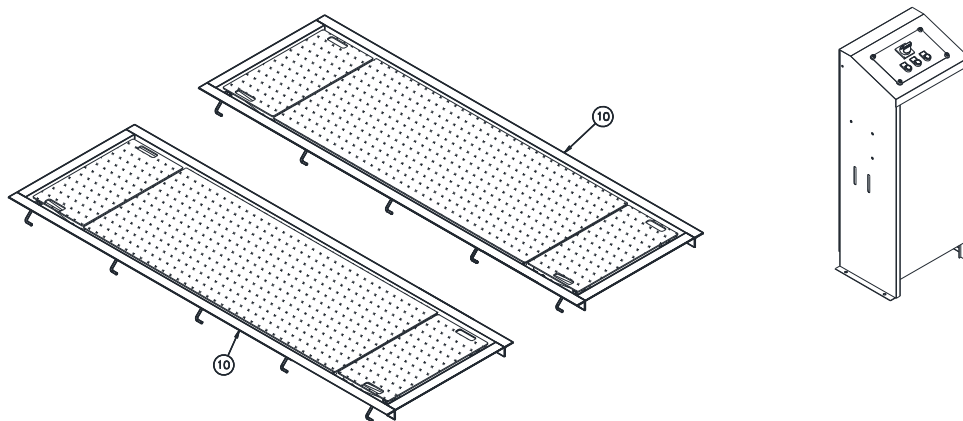

ITEM #	PART #	QTY/LIFT	DESCRIPTION
10	DX77-01	2	FLUSH MOUNT PIT FRAME

## **REVISIONS**

2020/06/17 – UPDATED FRONT COVER ADDRESS

2024/04/04 – UPDATED ANSI/ALI REFERENCE MATERIAL. UPDATED ANCHORING REFERENCE. PG. 8.  
ADDED ANSI STANDARDS REFERENCE STATEMENT SECTION. PG. 4.