

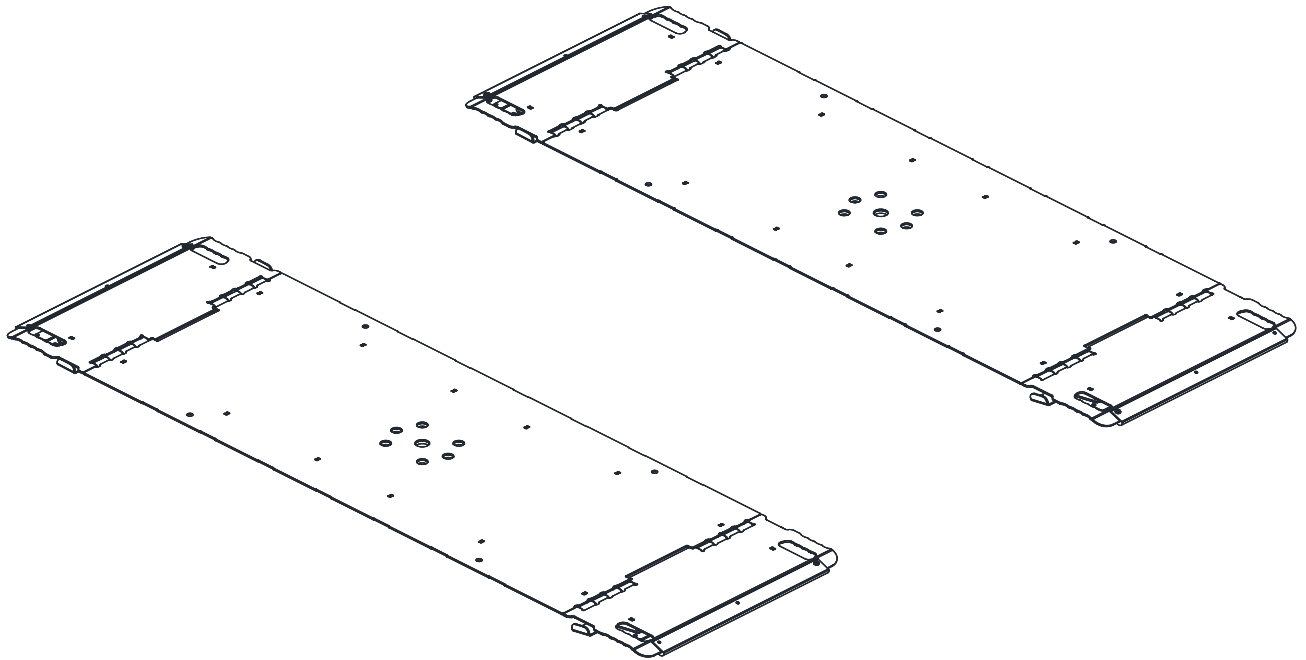

INSTALLATION & OPERATION MANUAL SUPPLEMENT
EVXP9 PAD ADAPTER



FOR MODEL EV1020 & EV1020QC
9,000 LBS CAPACITY

2311 SOUTH PARK RD LOUISVILLE, KENTUCKY 40219
EMAIL: SALES@CHALLENGERLIFTS.COM WEB SITE: WWW.CHALLENGERLIFTS.COM

OFFICE 800-648-5438 / 502-625-0700 FAX 502-587-1933

Read entire manual before assembling, installing, operating, or servicing this equipment. Proper maintenance and inspection is necessary for safe operation. DO NOT operate a damaged lift.

General Specifications

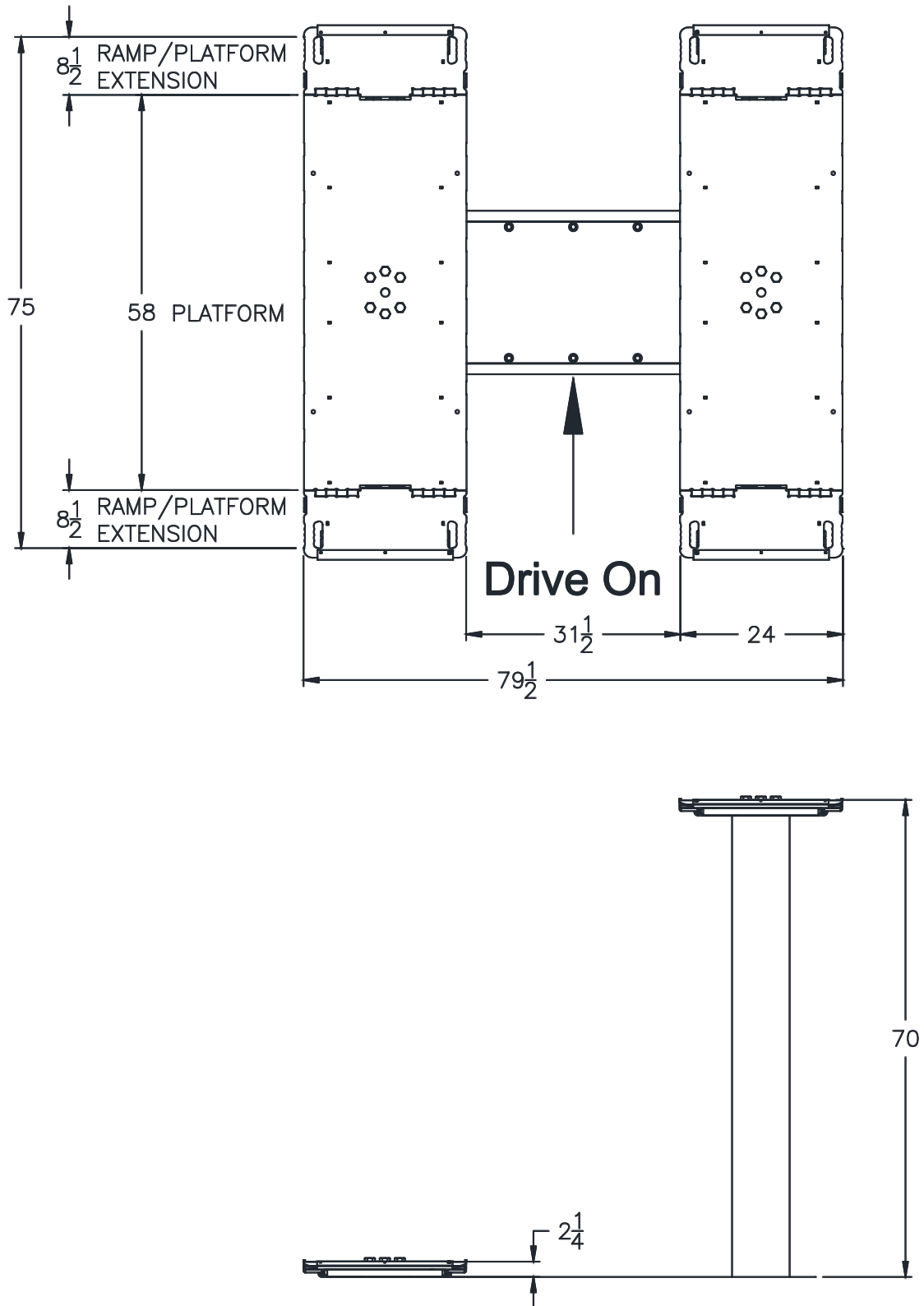

Fig. 1 GENERAL SPECIFICATIONS

* Drive-Over Height is affected by bay floor. The floor should be level and in the same plane within $\frac{3}{8}$ " over the area of the Lift Pads.

EVXP9-R2 Pad Adapter for Model EV1020

Installation, Operation, and Maintenance

RECEIVING

The shipment should be thoroughly inspected as soon as it is received. The signed bill of lading is acknowledgement by the carrier of receipt in good condition of shipment covered by our invoice.

If any of the goods called for on this bill of lading are shorted or damaged, do not accept them until the carrier makes a notation on the freight bill of the shorted or damaged goods. Do this for your own protection.

NOTIFY **Challenger Lifts** AT ONCE if any hidden loss or damage is discovered after receipt.

IT IS DIFFICULT TO COLLECT FOR LOSS OR DAMAGE AFTER YOU HAVE GIVEN THE CARRIER A CLEAR RECEIPT.

File your claim with **Challenger Lifts** promptly. Support your claim with copies of the bill of lading, freight bill, and photographs, if available.

Component Packing List

PART #	QTY/ LIFT	DESCRIPTION
10363-10-EV-R2	2	Pad Adapter Weld
10363-30	4	Ramp / Platform Extension Assembly
10362-40	4	Ramp Hinge Pin
40126	8	1/8 x 1-1/2 Cotter Pin
EVXP9-HW-A	1	Hardware Box

SAFETY NOTICES AND DECALS

For your safety, and the safety of others, read and understand all of the safety notices and decals included here.

READ ENTIRE SUPPLEMENT AND THE LIFT MANUAL BEFORE ASSEMBLING, INSTALLING, OPERATING, OR SERVICING THIS EQUIPMENT.

PROPER MAINTENANCE AND INSPECTION IS NECESSARY FOR SAFE OPERATION.

DO NOT OPERATE A DAMAGED LIFT.

Safety decals similar to those shown here are found on a properly installed lift. Be sure that all safety decals have been correctly installed on the Power Unit reservoir. Verify that all authorized operators know the location of these decals and fully understand their meaning. Replace worn, faded, or damaged decals promptly.



Do not attempt to raise a vehicle on the lift until the lift has been correctly installed

and adjusted as described in this supplement and the lift manual.

Read operating and safety manuals before using lift.

Proper maintenance and inspection is necessary for safe operation.

SAFETY INSTRUCTIONS

If attachments, accessories or configuration modifying components that are located in the load path, affect operation of the lift, affect the lift electrical listing or affect intended vehicle accommodation are used on this lift and, if they are not certified for use on this lift, then the certification of this lift shall become null and void. Contact the participant for information pertaining to certified attachments, accessories or configuration modifying components.

©2007 by ALL, Inc. www.alllift.org www.wilsiao1.com

Do not operate a damaged lift.

The messages and pictographs shown are generic in nature and are meant to generally represent hazards common to all automotive lifts regardless of specific style.

Funding for the development and validation of these labels was provided by the Automotive Lift Institute, PO Box 33116 Indialantic, FL 32903

They are protected by copyright. Set of labels may be obtained from ALL or its member companies.

© 1992 by ALL, Inc. ALPWL1014

CAUTION

Lift to be used by trained operator only.

CAUTION

Authorized personnel only in lift area.

WARNING

Clear area if vehicle is in danger of falling.

WARNING

Position vehicle with center of gravity midway between adapters.

CAUTION

Use vehicle manufacturer's lift points.

CAUTION

Always use safety stands when removing or installing heavy components.

WARNING

Remain clear of lift when raising or lowering vehicle.

WARNING

Avoid excessive rocking of vehicle while on lift.

CAUTION

Use height extenders when necessary to ensure good contact.

CAUTION

Auxiliary adapters may reduce load capacity.

WARNING

Do not override self-closing lift controls.

WARNING

Keep feet clear of lift while lowering.

The messages and pictographs shown are generic in nature and are meant to generally represent hazards common to all automotive lifts regardless of specific style.

Funding for the development and validation of these labels was provided by the Automotive Lift Institute, PO Box 33116 Indialantic, FL 32903.

They are protected by copyright. Set of labels may be obtained from ALL or its member companies.

© 1992 by ALL, Inc. ALPWL1014

The messages and pictographs shown are generic in nature and are meant to generally represent hazards common to all automotive lifts regardless of specific style.

Funding for the development and validation of these labels was provided by the Automotive Lift Institute, PO Box 33116 Indialantic, FL 32903.

They are protected by copyright. Set of labels may be obtained from ALL or its member companies.

© 1992 by ALL, Inc. ALPWL1014

INSTALLATION

1. The EVXP9 Pad Adapter is designed for the model EV1020 lift.
2. With the plungers raised slight (1"-2") to avoid damaging the wiper. Position the Platform over the piston with the Inside Reinforcement Gusset toward the center of the lift, see **Fig 2**. Attach the platform to the plunger using the 7/8-9x 3-1/2 cap screws and lock washers provided and torque to 120 ft-lbs. Repeat for other platform and plunger. Insert the Finishing Plug into both Platforms.

Note: Platforms are Identical, but must be oriented with Inside Reinforcement Gusset towards the center of the lift.



Fig. 2 PLATFORM ORIENTATION

RAMP / PLATFORM EXTENSION

3. Install each of the four (4) identical Ramp Assemblies using the 9/16" diameter Hinge Pin and two (2) Cotter Pins, **Fig. 3**. The Platform Extension Latch Plate should extend up inside the end of the Main Structure.

Hint: Secure a cotter pin to one end of the hinge pin and insert the other end of the pin all the way into an outer hinge tube on the platform. It will rest there and even carry the weight of one corner of the ramp. This allows one hand to hold and balance the ramp assembly while using the other hand to slide the pin into the remaining hinge tubes. Secure the hinge pin with the second cotter pin.

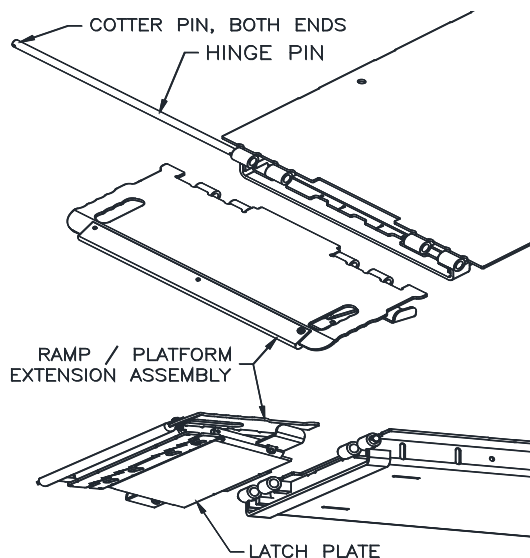

Fig. 3 INSTALLING THE RAMPS

RAMP SLIDES

4. Install a Ramp Slide to the bottom of each of the four Ramps. Orient the thick lobe portion of the Ramp Slide down, and secure it with three (3) 1/4" Phillips Pan Head Screws and Flanged Locking Nuts, **Fig. 4**.

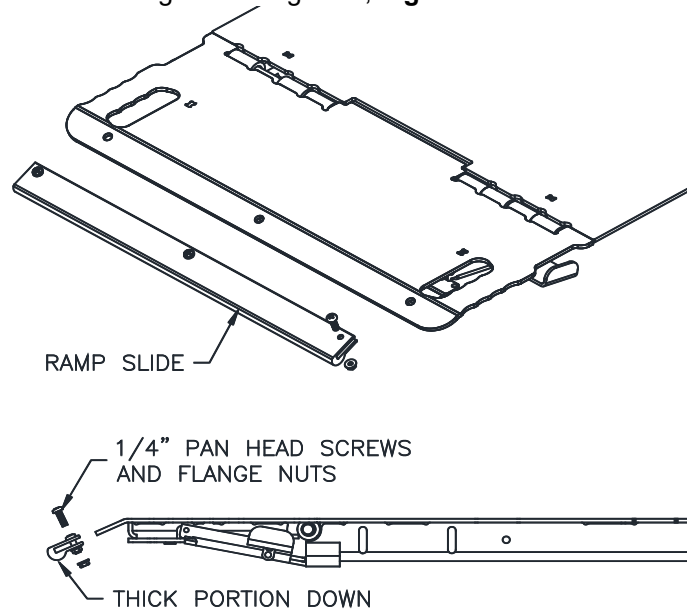

Fig. 4 INSTALLING THE RAMP SIDES

PLATFORM EXTENSION LEVELING

5. Raise each Ramp until the Latch Plate located beneath the Ramp locks into the base of the Platform. Raise the lift to full height so adjustments can be made to the bottom of the Ramps. Place a straight-edge (2 ft. minimum) fore-&-aft across one of the Ramp Hinge areas, **Fig. 5**.

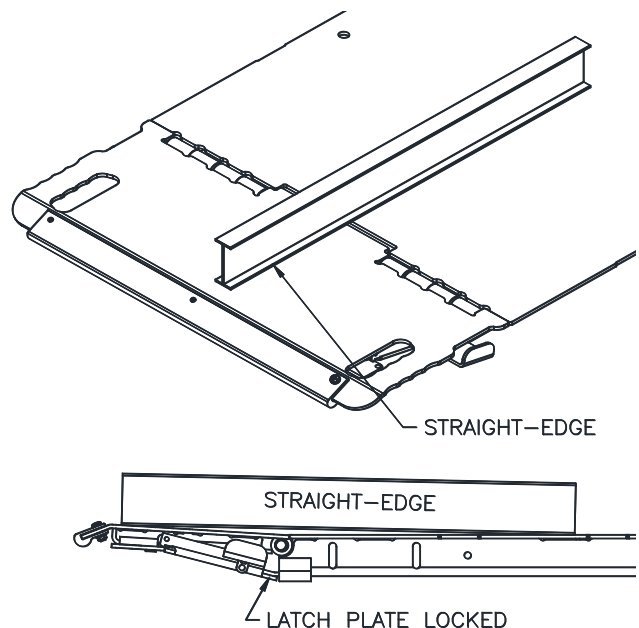

Fig. 5 LEVELING THE RAMPS WITH A STRAIGHT-EDGE

EVXP9-R2 Pad Adapter for Model EV1020
Installation, Operation, and Maintenance

- Slightly loosen the four (4) Flat-Head Screws securing the Movable Saw Tooth Adjustment Bar, **Fig. 6**. Tap on either end of the Adjustment Bar with a hammer to change the pitch of the Ramp. Once the Ramp is adjusted flat with the Platform as indicated by the Straight-Edge, **Fig. 5**, retighten the Flat Head Screws to lock the Adjustment bar into position.

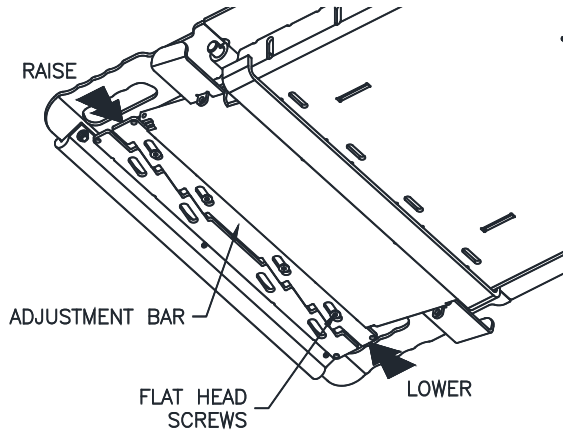
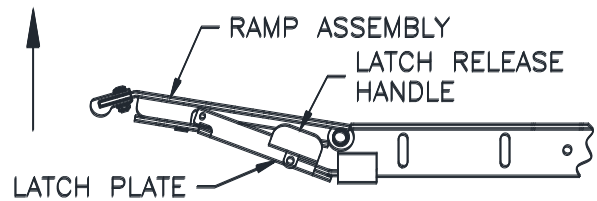

Fig. 6 MOVING THE SAW-TOOTHED ADJUSTMENT BAR

RAMP LATCH

- Check the function of the Ramp Latch, **Fig. 7**. Raise the tail of the ramp with one hand and raise the Latch Release Handle with the other. While still holding the Latch Release Handle, lower the tail end of the ramp. It should drop approximately 55 degrees. Release the Latch Release Handle and raise the tail of the ramp again until the Latch Plate engages. The Ramp should once again be flat with the surface of the Main Structure as set in **Step 5**.



- WHEN RAMP IS RAISED, LATCH SHOULD AUTOMATICALLY ENGAGE THE END OF THE MAIN STRUCTURE

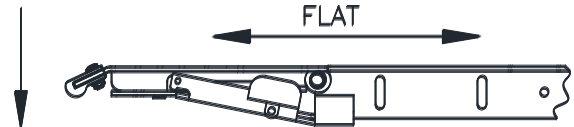

- WHEN RAMP IS RELEASED, IT SHOULD COME TO REST FLAT WITH THE MAIN STRUCTURE

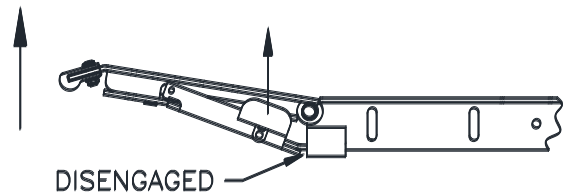

- WHEN RAMP AND LATCH RELEASE HANDLE ARE BOTH RAISED, THE LATCH PLATE SHOULD DISENGAGE FROM THE MAIN STRUCTURE

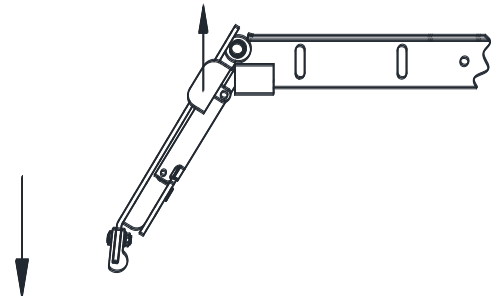

- LOWERING THE RAMP WHILE CONTINUING TO HOLD THE LATCH RELEASE HANDLE ALLOWS THE RAMP TO LOWER APPROXIMATELY 55° FROM HORIZONTAL

Fig. 7 CHECKING RAMP LATCH FUNCTION

- Repeat **Step 7** for the remaining three (3) ramps.

EVXP9-R2 Pad Adapter for Model EV1020
Installation, Operation, and Maintenance

OPERATION PROCEDURE

SAFETY NOTICES AND DECALS

This product is furnished with graphic safety warning labels, which are reproduced on page 3 of these instructions. Do not remove or deface these warning labels or allow them to be removed or defaced. For your safety, and the safety of others, read and understand all of the safety notices and decals included.

OWNER/EMPLOYER RESPONSIBILITIES

This lift has been designed and constructed according to ANSI/ALI ALCTV standard. The standard applies to lift manufacturers, as well as to owners and employers. The owner/employer's responsibilities as prescribed by ANSI/ALI ALOIM, are summarized below. For exact wording refer to the actual standard provided with this manual in the literature pack.

The Owner/Employer shall ensure that lift operators are qualified and that they are trained in the safe use and operation of the lift using the manufacturer's operating instructions; ALI/SM, *ALI Lifting it Right safety manual*; ALI/ST, *ALI Safety Tips card*; ANSI/ALI ALOIM, *American National Standard for Automotive Lifts-Safety Requirements for Operation, Inspection and Maintenance*; ALI/WL Series, *ALI Uniform Warning Label Decals/Placards*; and in case of frame engaging lifts, ALI/LP-GUIDE, *Vehicle Lifting Points/Quick Reference Guide for Frame Engaging Lifts*.

The Owner/Employer shall establish procedures to periodically inspect the lift in accordance with the lift manufacturer's instructions or ANSI/ALI ALOIM, *American National Standard for Automotive Lifts-Safety Requirements for Operation, Inspection and Maintenance*; and the employer shall ensure that the lift inspectors are qualified and that they are adequately trained in the inspection of the lift.

The Owner/Employer shall establish procedures to periodically maintain the lift in accordance with the lift manufacturer's instructions or ANSI/ALI ALOIM, *American National Standard for Automotive Lifts-Safety Requirements for Operation, Inspection and Maintenance*; and the employer shall ensure that the lift maintenance personnel are qualified and that they are adequately trained in the maintenance of the lift.

The Owner/Employer shall maintain the periodic inspection and maintenance records recommended by the manufacturer or ANSI/ALI ALOIM, *American National Standard for Automotive Lifts-Safety Requirements for Operation, Inspection and Maintenance*.

The Owner/Employer shall display the lift manufacturer's operating instructions; ALI/SM, *ALI Lifting it Right safety manual*; ALI/ST, *ALI Safety Tips card*; ANSI/ALI ALOIM, *American National Standard for Automotive Lifts-Safety Requirements for Operation, Inspection and Maintenance*; and in the

case of frame engaging lift, ALI/LP-GUIDE, *Vehicle Lifting Points/Quick Reference Guide for Frame Engaging Lifts*; in a conspicuous location in the lift area convenient to the operator.

IMPORTANT SAFETY INSTRUCTIONS

When using your garage equipment, basic safety precautions should always be followed, including the following:

1. Read all instructions.
2. Care must be taken as burns can occur from touching hot parts.
3. To reduce the risk of fire, do not operate equipment in the vicinity of open containers of flammable liquids (gasoline).
4. Keep hair, loose clothing, fingers, and all parts of body away from moving parts.
5. Use only as described in this manual. Use only manufacturer's recommended attachments.
6. ALWAYS WEAR SAFETY GLASSES. Everyday eyeglasses only have impact resistant lenses, they are not safety glasses.

SAVE THESE INSTRUCTIONS

EVXP9-R2 Pad Adapter for Model EV1020
Installation, Operation, and Maintenance

LIFTING A VEHICLE

- 1) The ramps can be used as a loaded lifting surface only when in the full UP and Locked position. Ramps must be fully released and in the Down position during driving on / off of the platforms
- 2) Ensure that the platforms are completely lowered, the ramps are unlatched (resting on the floor), and the spotting blocks are clear of the drive path.
- 3) Center the vehicle between the columns in the service bay and position the vehicle's center of gravity midpoint between the columns. **NOTE: the center of gravity is based on the weight distribution and is not the same as the center point of the vehicle.**

DO NOT EXCEED 4500 POUNDS PER PLATFORM.

ALWAYS USE A PROVIDED SPOTTING BLOCK AT EACH VEHICLE LIFTING POINT TO AVOID DAMAGE TO VEHICLE UNDERCARRIAGE AND LIFT.

DO NOT ATTEMPT TO LIFT THE VEHICLE WITH ONLY ONE PLATFORM, AS THIS WILL VOID THE WARRANTY

DO NOT PLACE THE VEHICLE IN THE SERVICE BAY BACKWARDS.

- 4) Raise the ramps and make sure it is secure.

NOTE: The sloped ramps may be lifted to lock automatically into a horizontal position to extend the lifting surface of the platform.

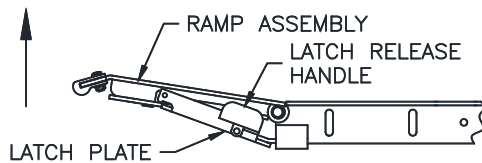

- ① WHEN RAMP IS RAISED, LATCH SHOULD AUTOMATICALLY ENGAGE THE END OF THE MAIN STRUCTURE

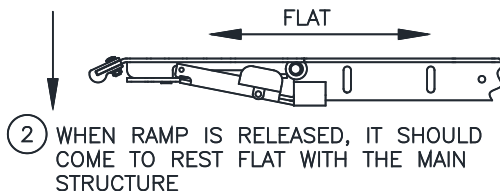

- ② WHEN RAMP IS RELEASED, IT SHOULD COME TO REST FLAT WITH THE MAIN STRUCTURE

- 5) Position the spotting blocks under the vehicle lifting points so that all four pads make contact with the vehicle simultaneously. Each spotting block should be centered with the vehicle lifting point. No portion of the spotting block should extend beyond the edge of the platform.

REFER TO THE VEHICLE MANUFACTURERS SERVICE MANUAL, TECHNICAL BULLETINS, "VEHICLE LIFTING POINTS GUIDE" (ALI/LP-GUIDE) OR OTHER PUBLICATIONS TO LOCATE THE RECOMMENDED LIFTING POINTS.

- 6) Raise the lift until the spotting blocks makes contact with the vehicle lifting points.

The vehicle should remain level during lifting.



Before raising, ensure that spotting blocks do not extend beyond the edge of the platform to avoid damage to the lift. Each spotting block should be centered with the vehicle lifting point.

- 7) Raise the lift until all four wheels are off the ground. Test the stability of the vehicle by attempting to rock the vehicle. Check spotting blocks for secure contact with vehicle lift points. If the vehicle seems unstable, lower the lift and readjust. If the vehicle is stable, raise the vehicle to a height a few inches above the desired working height.
- 8) Lower the vehicle by depressing the lowering valve handle until the safety latches on both columns engage. The vehicle should remain level when both latches are engaged. If one side engages and the other continues to descend, stop lowering the vehicle, raise it several inches, and try again to engage both latches.

Always lower lift into locks before entering the area beneath the vehicle.

Always use auxiliary stands when removing or installing heavy components.

EVXP9-R2 Pad Adapter for Model EV1020

Installation, Operation, and Maintenance

LOWERING A VEHICLE

- 1) Ensure that the area under the vehicle is clear of personnel, tools, and any foreign objects / debris.



WARNING

Failure to clear the floor of foreign objects / debris could hinder proper engagement of the Ramp / Extension Latch resulting in unsatisfactory lift performance, property damage, or personal injury.

- 2) Raise the vehicle until both latches are free.
- 3) Disengage the locks by pulling and hold the lock release lever.
- 4) Lower the vehicle by depressing the lowering valve handle.
- 5) Continue to lower the vehicle until the lift platforms are resting on the floor.
- 6) Remove the spotting blocks and disengage the Ramp / Platform Extensions so all four ramps are resting on the floor.

RAMP/PLATFORM EXTENSION

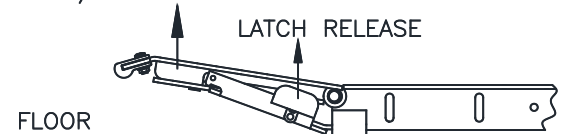

- ① RAISE THE RAMP AND LATCH RELEASE HANDLE TO DISENGAGE THE PLATFORM EXTENSION

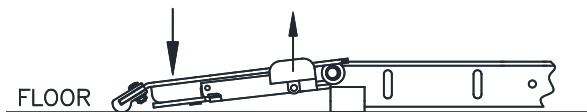

- ② LOWER THE RAMP TO THE FLOOR WHILE CONTINUING TO HOLD THE LATCH RELEASE HANDLE

LOSS OF POWER

If for any reason the lift will not raise off the locks or the locks will not retract, consult factory authorized personnel.

DO NOT OVERRIDE ANY SAFETY FEATURE IN AN ATTEMPT TO LOWER THE LIFT.

MAINTENANCE

To avoid personal injury, permit only qualified personnel to perform maintenance on this equipment. Maintenance personnel should follow lockout/tagout instructions per ANSI Z244.1.

The following maintenance points are suggested as the basis of a routine maintenance program. The actual maintenance program should be tailored to the installation and include a record of each planned maintenance activity and repair maintenance activity performed. Refer to the maintenance section of the ANSI/ALI ALOIM booklet (blue book) provided with the lift.

- **IF LIFT STOPS SHORT OF FULL RISE OR CHATTERS, CHECK FLUID LEVEL AND BLEED BOTH CYLINDERS PER INSTALLATION INSTRUCTIONS.**
- Replace all Safety, Warning or Caution Labels if missing or damaged (**See Installation instructions page 3.**)

DAILY

- Keep lift components clean.
- Check for loose or broken parts.
- Check hydraulic system for fluid leaks.
- Check spotting blocks for damage or excessive wear. Replace as required with genuine Challenger Lifts parts.
- Check Ramp / Platform Extension function per Installation Step 15.
- Check lock release activation. When properly adjusted, the idler column lock should rest firmly against the back of the column when engaged and against the spring mount tab when disengaged.

WEEKLY

- Check synchronizer cables and sheaves for wear. Replace as required with genuine Challenger Lifts parts.
- Check synchronizer cable tension per Installation Instructions. Adjust if necessary.

MONTHLY

- Torque concrete anchor bolts to 80 ft-lbs.
- Visually inspect concrete floor for cracks and/or spalls within 12" of base plate
- Check overhead shutoff switch. While raising lift, operate overhead shutoff bar. Power Unit motor should stop when bar is raised.
- Lubricate carriage slide tracks with heavy viscous grease. (Grease all (4) corners of both columns.)

If any problems are encountered, contact your local service representative.

EVXP9-R2 Pad Adapter for Model EV1020
Installation, Operation, and Maintenance

PARTS BREAKDOWN EVXP9

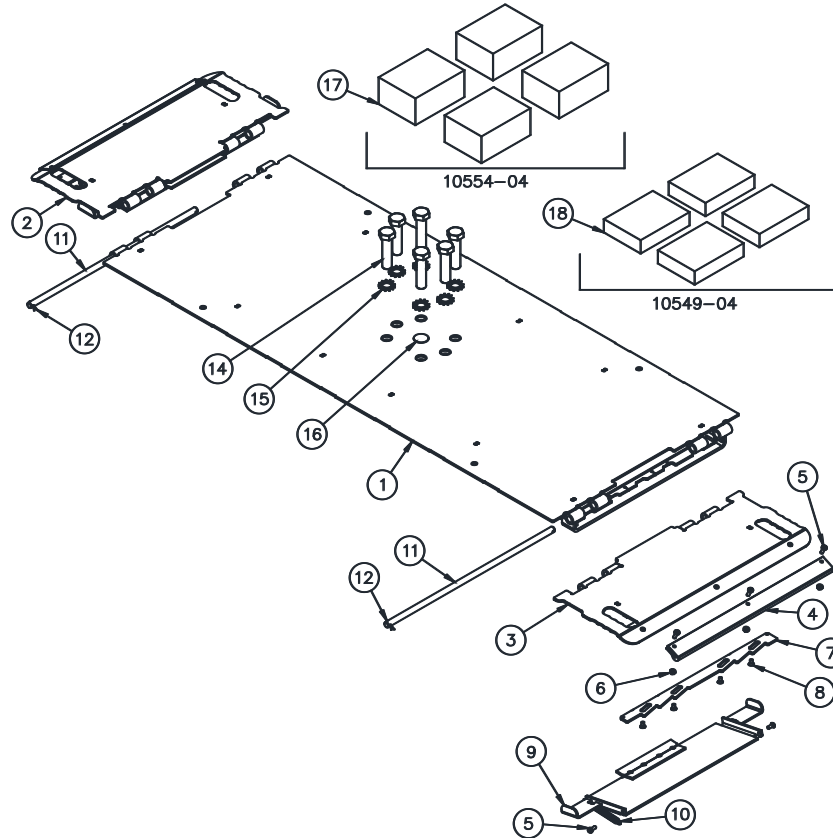

ITEM	PART NO.	QTY / LIFT	DESCRIPTION
1	10363-10-EV-R2	2	PAD ADAPTER WELD, EVXP9
2	10363-30	4	RAMP ASSEMBLY (INCLUDES ITEMS 3-10)
3	10363-31	4	RAMP WELD
4	40168	4	RAMP SLIDE
5	31062	12	1/4-20NC x 3/4 PAN HEAD SCREW
6	40085	12	1/4-20NC HEX FLANGE NUT
7	10363-34	4	RAMP LATCH STOP, SAW TOOTH
8	10363-12	16	1/4-20NC x 1/2 FLAT SOCKET HEAD CAP SCREW
9	10363-35	4	RAMP LATCH WELD
10	40139	8	EXTENSION SPRING, 1/2 x 3 1/4
11	10362-40	4	RAMP HINGE PIN
12	40126	8	COTTER PIN
13	RJAB-07	2	CAPACITY LABEL, 9000 LBS
14	16473	12	7/8-9 x 3-1/2" HEX HEAD CAP SCREW
15	16154	12	7/8 EXTERNAL TOOTH LOCK WASHER
16	16160	2	PLUG 1-1/4"
17	10554-04	1	3" RUBBER BLOCK SET (4 pcs.)
	10554-01	4	3" RUBBER BLOCK
18	10549-04	1	1-1/2" RUBBER BLOCK SET (4 pcs.)
	63101-01	4	1-1/2" RUBBER BLOCK

OPTIONAL VERSAHANGER PACKAGE – BASIC THK-EVXP9-STD

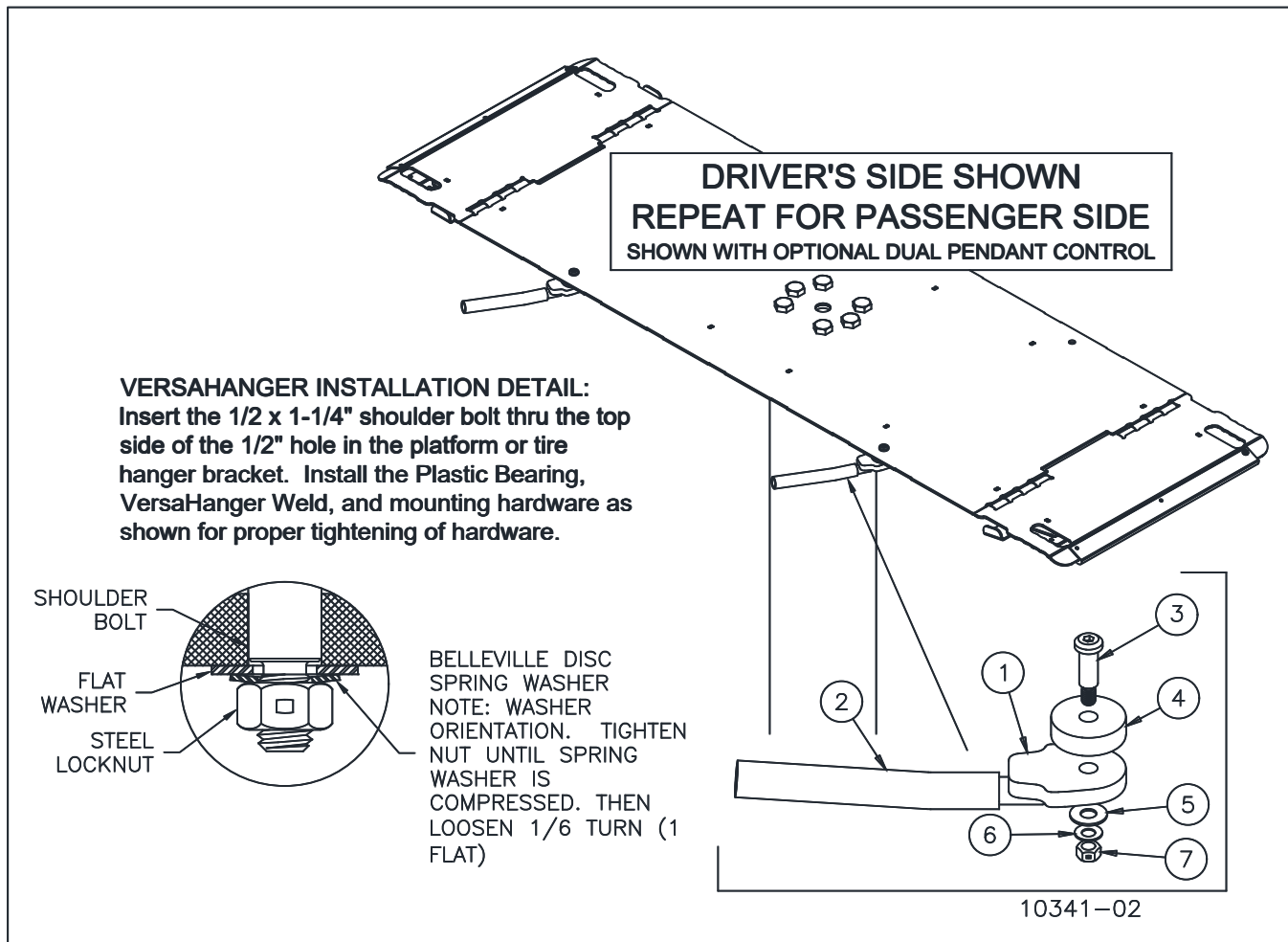

ITEM	PART NO.	QTY / LIFT	DESCRIPTION
1	10341-06A	4	VERSAHANGER WELD
2	10341-27	4	WHEEL PROTECTOR HOSE
3	10341-23M	4	1/2 x 1 1/4 SHOULDER BOLT, MACHINED
4	10341-14	4	VERSAHANGER BEARING
5	31036	4	3/8 FLAT WASHER
6	10341-29	4	BELLEVILLE DISC SPRING WASHER, SS
7	10341-24	4	3/8-16NC STEEL LOCKNUT

EVXP9-R2 Pad Adapter for Model EV1020
Installation, Operation, and Maintenance

REVISIONS

2019/06/04 – GUSSET WAS ADDED TO INSIDE EDGE OF THE PLATFORM. STEP 2 WAS ADDED.
2020/08/18 – ADDED VERSAHANGER PACKAGE TO THE PARTS BREAKDOWN.
2023/12/12 – UPDATED ANSI/ALI REFERENCE MATERIAL.