

CL Challenger Lifts

Installation, Operation & Maintenance Manual

MODEL RJ4.5

ROLLING JACK

(CL4P9 Series 4-Post only)

4,500 lbs Capacity



2311 South Park Rd, Louisville, Kentucky 40219

Email: sales@challengerlifts.com Web site: www.challengerlifts.com

Office 800-648-5438 / 502-625-0700 Fax 502-587-1933

IMPORTANT: READ THIS MANUAL COMPLETELY
BEFORE INSTALLING or OPERATING JACK

⚠ CAUTION

- ◆ Before using this product, read and fully understand the operating instructions and all decals on the product. This is necessary to prevent injury to the operator and damage to the product.
- ◆ Roll jack forward before moving vehicle on or off lift.
- ◆ Do not attempt to use this jack for anything other than its intended purpose.
- ◆ If jack begins to tilt as the vehicle is raised, STOP! Lower jack and reposition the vehicle.
- ◆ Do not use this jack if it is visibly worn, distorted or damaged.
- ◆ Always wear appropriate eye protection.

⚠ WARNING

- ◆ Maximum lift capacity of this jack is 4500 lbs (2041 kg)
Exceeding this could result in severe personal injury or death.
- ◆ Lift vehicle at manufacturer's recommended pick-up points only.
Vehicle weight must be evenly distributed on each jack lift pad.
- ◆ Keep fingers and hands clear of all pinch points at all times.

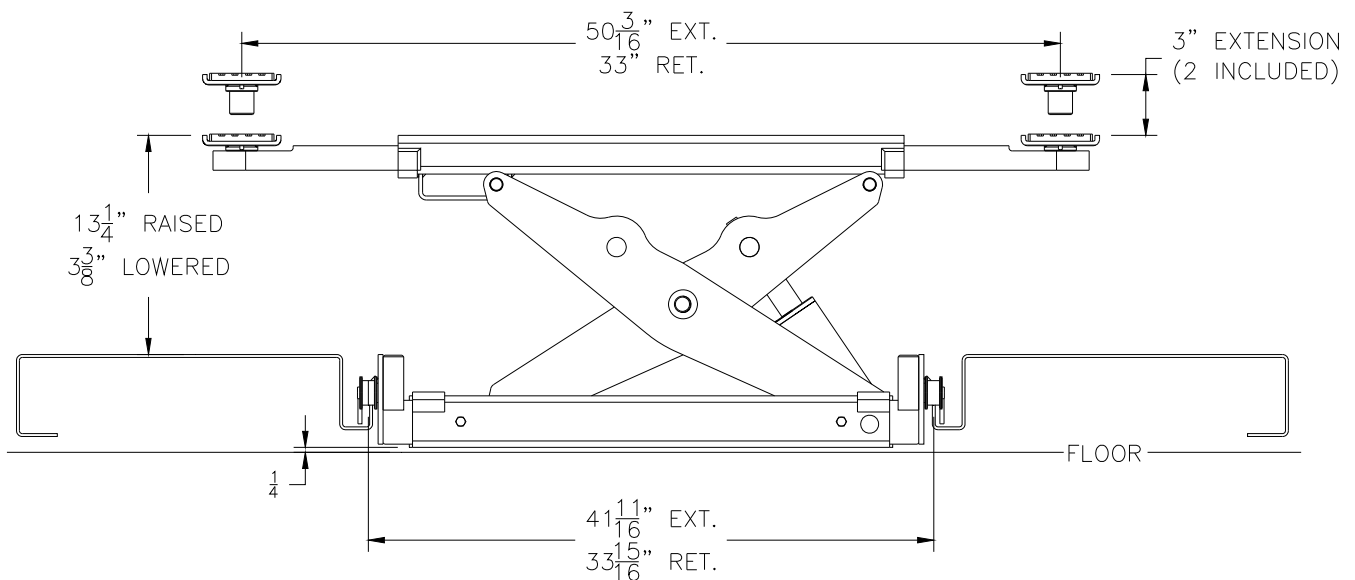

Fig. 1

RJ4.5 Installation, Operation and Maintenance Manual

INSTALLATION

- 1) Place jack assembly on lift rack rails.
- 2) Once side members are adjusted and jack is centered between the rails, tighten the (4) hex bolts (2 per side) to lock in place, Fig 2.

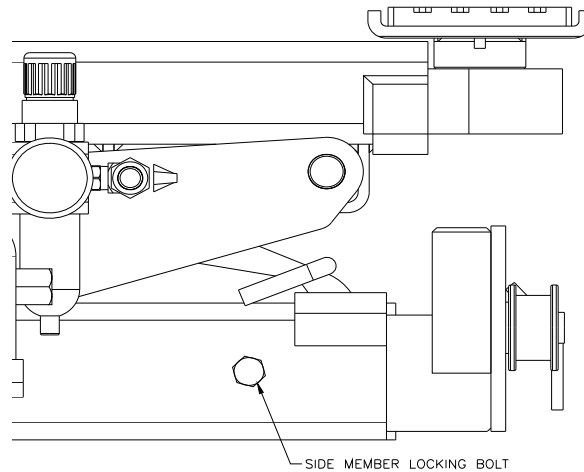

Fig. 2

Operation

Note: Before lifting a vehicle, operate the jack through a couple of cycles to become familiar with the controls.

- 1) Roll jack forward before moving vehicle on lift rack. Be sure vehicle is centered on rack, apply parking brake and chock wheels.
- 2) Roll jack(s) to the vehicle manufacturer's recommended pick-up points. Extend lift pad arms to proper lift points. Use lift pad spacers if necessary.
- 3) Raise jack by pumping the jack handle.
- 4) Raise vehicle to desired height.
- 5) Lower jack onto lock.
- 6) To lower jack completely, raise off of lock and turn the valve handle counter clockwise. Push lift pad arms in, remove lift pad spacers (if used). Roll jack forward before moving vehicle off rack.

Loss of power

If for any reason the lift will not raise off the locks or the locks will not retract, consult factory authorized personnel.

DO NOT OVERRIDE ANY SAFETY FEATURE IN AN ATTEMPT TO LOWER THE LIFT.

Maintenance

Daily: Inspect jack and its components for damage or excessive wear. Replace parts as required. See parts list. Inspect hydraulic system for leaks.

Annually: Check hydraulic pump oil level if jack is not achieving full rise height. When jack is completely lowered, remove pump from base, hold pump vertical then remove breather plug (knurled screw on pump end) and check oil level. Oil should be at top of filler plug hole. Recommended Oil: AW32- 10wt hydraulic oil, non-foaming, anti rust.

IMPORTANT!

Failure to keep lift free of corrosive agents and solvents will lead to reduced service life, which could result in property damage and/or personal injury. If any problems are encountered, contact your local service representative.

Parts Breakdown

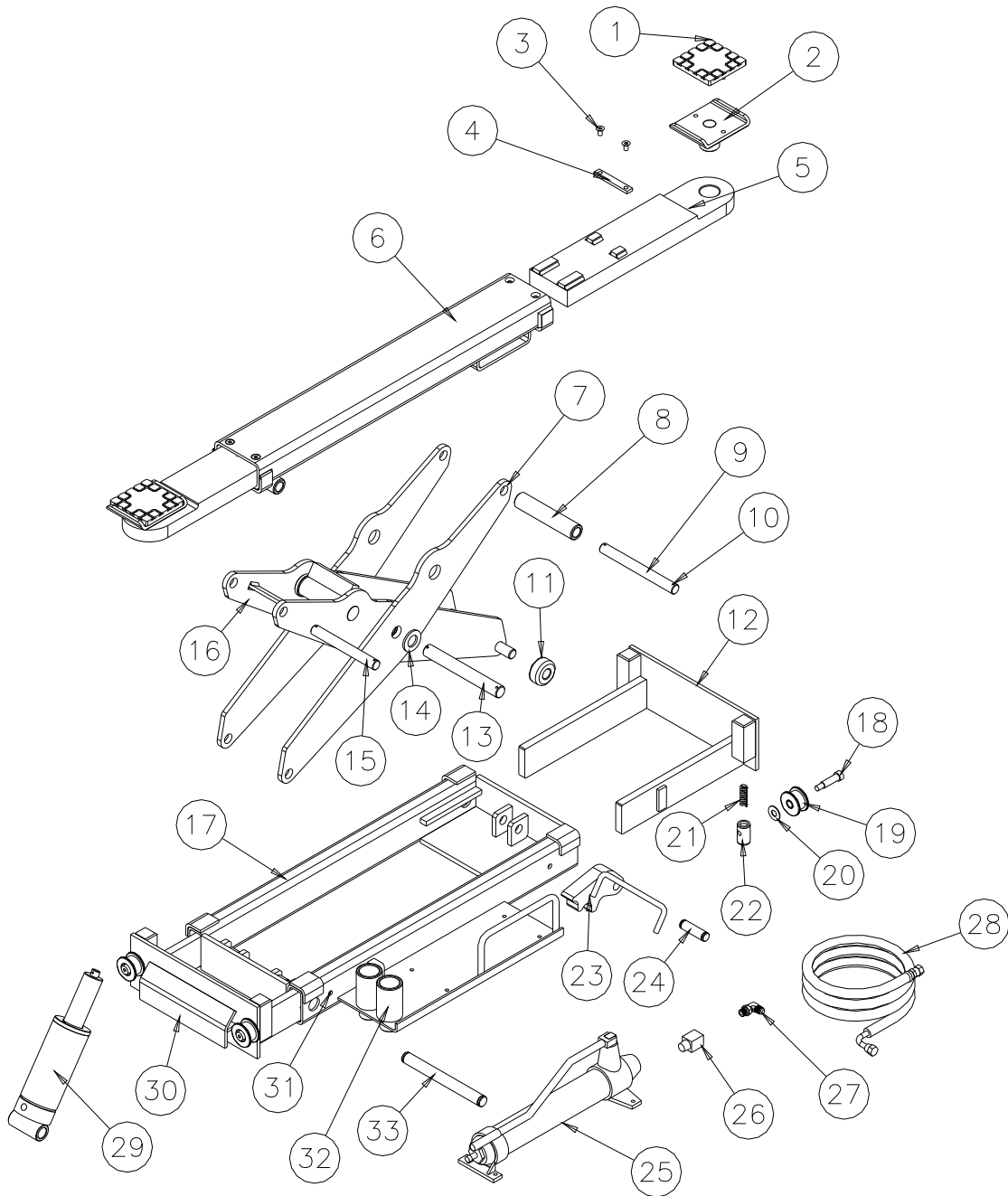

RJ4.5 Installation, Operation and Maintenance Manual

Item Number	Part Number	Qty/Jack	Description
1	A11052	2	Rubber Insert
1A	VS10-35-05	4	M6 Nylon Locknut
2	RJ4.5-04	2	Foot Pad
3	VS10-31-08	4	M8 x 12 Flat Head Screw
4	RJ6-19	2	Stop Bar
5	RJ4.5-02	2	Arm
6	RJ6-01CH	1	Sleeve
7	RJ6-07CH	2	Outer Scissor Plate
8	RJ6-06-04	1	Upper Pin Roller
9	RJ6-13	1	Upper Pin
10	VS10-20-10	6	5mm Roll Pin
10A	X10-099	4	20mm Washer
11	RJ6-18	2	Roller
12	RJ4.5-15A	2	Side Member Weld
13	RJ6-08	1	Main Pin
14	RJ6-23	2	Spacer Washer
15	RJ6-12	1	Upper Pin, Fixed End
16	RJ6-06CH	1	Internal Scissor
17	RJ4.5-11-00	1	Jack Body
18	RJ6-27CH	4	16mm Dia. Shoulder Bolt
19	RJ6-17CH	4	Wheel
20	RJ6-24CH	4	Nylon Washer
21	RJ6-26A	4	Compression Spring
22	RJ6-25CH	4	Carrier
23	RJ6-16CH	1	Lock
24	RJ6-20CH	1	Lock Pin
24A	RJ6-35	2	18mm Snap Ring
25	RJ45-31-00	1	4500 lb Hand Pump Rolling Jack
26	RJ4.5-30-00	1	Flow Restrictor Assembly
27	JSJ3-10-05	1	3/8-18 NPT x M14x1.5 90 Deg. Hyd. Fitting
28	RJ4.5-21	1	Hydraulic Hose
29	RJ6-09CH	1	Cylinder
30	RJ4.5-15-00	2	Side Member Assembly
31	X10-077	4	M10 x 25 HHCS
31A	RJ6-38	4	M10 Hex Nut
32	RJ6-05	2	3" Stack Pad
32A	RJ6-40	2	15mm Snap Ring
33	RJ6-14	1	Cylinder Pin

IMPORTANT!

Replace all worn, damaged, or broken parts with parts approved by **Challenger Lifts Inc.**
or with parts meeting **Challenger Lifts Inc.** specifications.

Contact your local Challenger Lifts Parts Distributor for pricing and availability.
(Call **Challenger Lifts Inc.** (502) 625-0700 for the Parts Distributor in your area)