

CL Challenger Lifts

Installation, Operation & Maintenance Manual

MODEL RJ9A / RJ9S

ROLLING JACK

(Model 44018 Series 4-Post only with runway spacing 33-15/16" to 41-11/16")

9,000 lbs Capacity

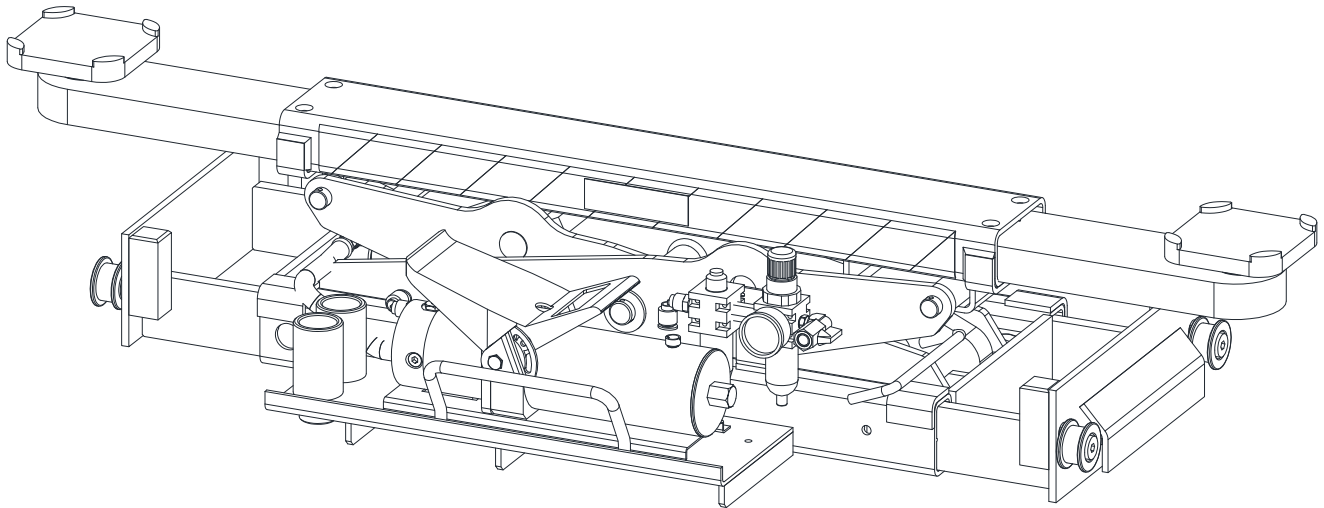

2311 South Park Rd, Louisville, Kentucky 40219

Email: sales@challengerlifts.com Web site: www.challengerlifts.com

Office 800-648-5438 / 502-625-0700 Fax 502-587-1933

IMPORTANT: READ THIS MANUAL COMPLETELY BEFORE
INSTALLING or OPERATING LIFT

CAUTION

- ◆ Before using this product, read and fully understand the operating instructions and all decals on the product. This is necessary to prevent injury to the operator and damage to the product.
- ◆ Roll jack forward before moving vehicle on or off lift.
- ◆ Do not attempt to use this jack for anything other than its intended purpose.
- ◆ If jack begins to tilt as the vehicle is raised, STOP! Lower jack and reposition the vehicle.
- ◆ Do not use this jack if it is visibly worn, distorted or damaged.
- ◆ Maximum air operating pressure not exceed 150 p.s.i.
- ◆ Always wear appropriate eye protection.

WARNING

- ◆ Lifting capacity of this jack is 9000lbs (Hydraulic Pressure at Cap. = 6300 psi) Exceeding this could result in severe personal injury or death.
- ◆ When the total lifting capacity of 2 rolling jacks differs from the rated capacity of the lift they are used on, the capacity of each jack should not exceed 1/2 the total capacity of the runways. Exceeding this could result in severe personal injury or death.
- ◆ Lift vehicle at manufacturer's recommended pick-up points only. Vehicle weight must be evenly distributed on each jack lift pad.
- ◆ Keep fingers and hands clear of all pinch points at all times.

Dimensions

Jack Model	RJ9A	RJ9S
4-Post Lift Used	44018AR, 44018XAR	44018, 44018E
A Rise Height From Runway (Min. /Max.)	4-3/4" / 14-5/8"	3-3/4" / 13-5/8"
B Arm Span (Min./Max.)	33" / 50-3/16"	33" / 50-3/16"
C Bottom Clearance	11/16"	1-1/16"
D Jack Rail Width (Min./Max.)	33-15/16" / 41-11/16"	33-15/16" / 41-11/16"
Lifting Capacity	9,000 lbs	9,000 lbs.
Max Load Per Arm/Pad	4,500 lbs	4,500 lbs

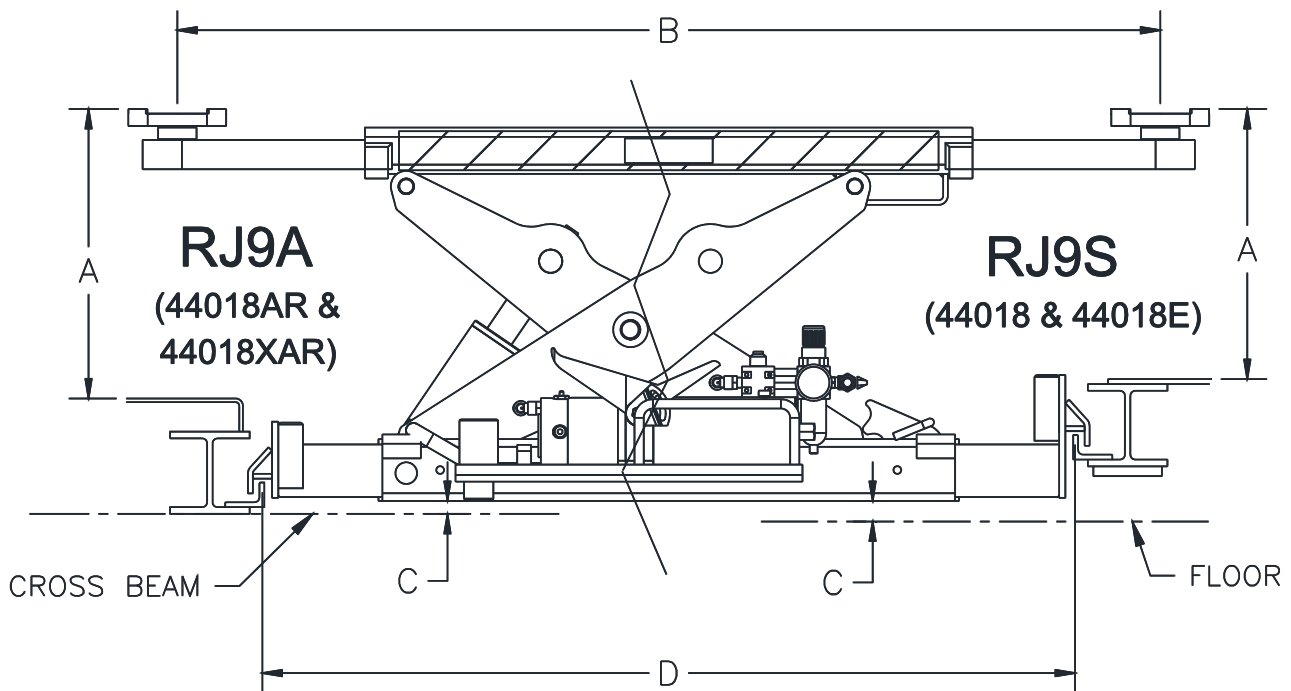

Fig. 1

RJ9 Installation, Operation and Maintenance Manual

INSTALLATION

- 1) Install a 1/4 NPT male quick disconnect coupling in air inlet of F.L.R. pre installed on jack. Match to shop fittings.
- 2) Place jack assembly on lift rack rails
- 3) Once side members are adjusted and jack is centered between the rails, tighten the (4) hex bolts (2 per side) to lock in place, Fig 2.

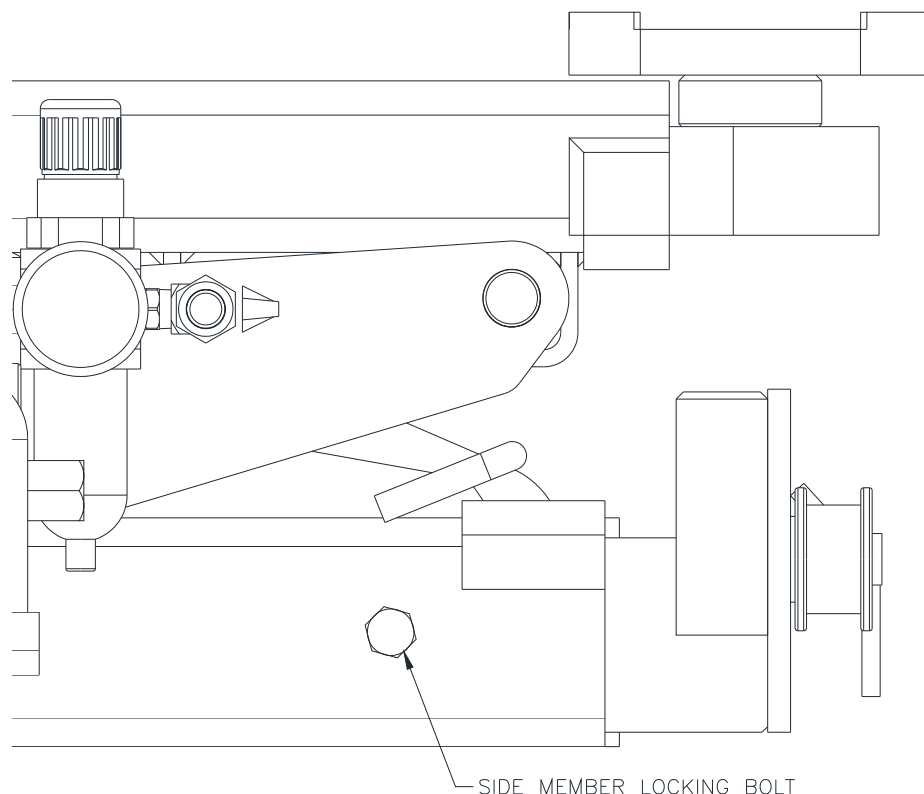

Fig. 2

Operation

Note: Before lifting a vehicle, operate the jack through a couple of cycles to become familiar with the controls.

- 1) Roll jack forward before moving vehicle on lift rack. Be sure vehicle is centered on rack, apply parking brake and chock wheels.
- 2) Roll jack(s) to the vehicle manufacturer's recommended pick-up points. Extend lift pad arms to proper lift points. Use lift pad spacers if necessary.
- 3) Raise jack by pushing on foot pedal on pump.
- 4) Raise vehicle to desired height.
- 5) Lower jack onto lock.
- 6) To lower jack completely, raise off of lock and while holding lock release handle open lower jack. Push lift pad arms in, remove lift pad spacers (if used). Roll jack forward before moving vehicle off rack.

Loss of power

If for any reason, the lift will not raise off the locks or the locks will not retract, consult factory authorized personnel.

DO NOT OVERRIDE ANY SAFETY FEATURE IN AN ATTEMPT TO LOWER THE LIFT.

Adjusting the Release Mechanism

- 1) Loosen the “Adjusting Screw”
- 2) Verify that the “Adjusting Plate” is free.
- 3) Depress the “Air Inlet Stem” with the “Foot Pedal”. The pump will now run and build pressure.
- 4) Release the “Foot Pedal”. The pump will stop running, but hydraulic pressure will be held.
- 5) With the “Foot Pedal” resting on the “Air Inlet Stem” rotate the “Adjusting Plate” clockwise until a stop is felt.

Note: If the end of the slot in the “Adjusting Plate” is met before a stop is felt, the “Adjusting Plate” must be repositioned one step counterclockwise on the “Hex Stem”, then repeat step #5.

- 6) Tighten the “Adjusting Screw”. The release mechanism is now properly set.

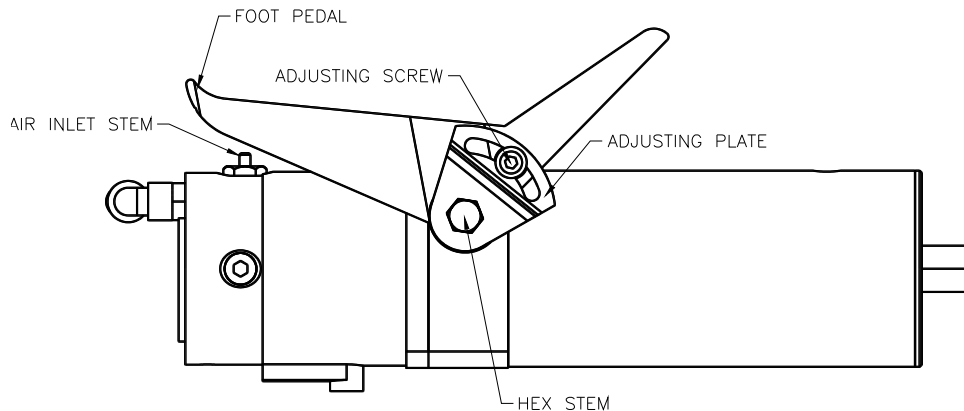

Maintenance

Daily: Inspect jack and its components for damage or excessive wear. Replace parts as required. See parts list.

Inspect air/hydraulic system for leaks. Check in-line lubricator oil level.

Annually: Check hydraulic pump fluid level. When jack is completely lowered remove breather plug and check oil level. Oil should be at top of filler plug hole.

IMPORTANT!

Failure to keep lift free of corrosive agents and solvents will lead to reduced service life, which could result in property damage and/or personal injury. If any problems are encountered, contact your local service representative.

Parts Breakdown

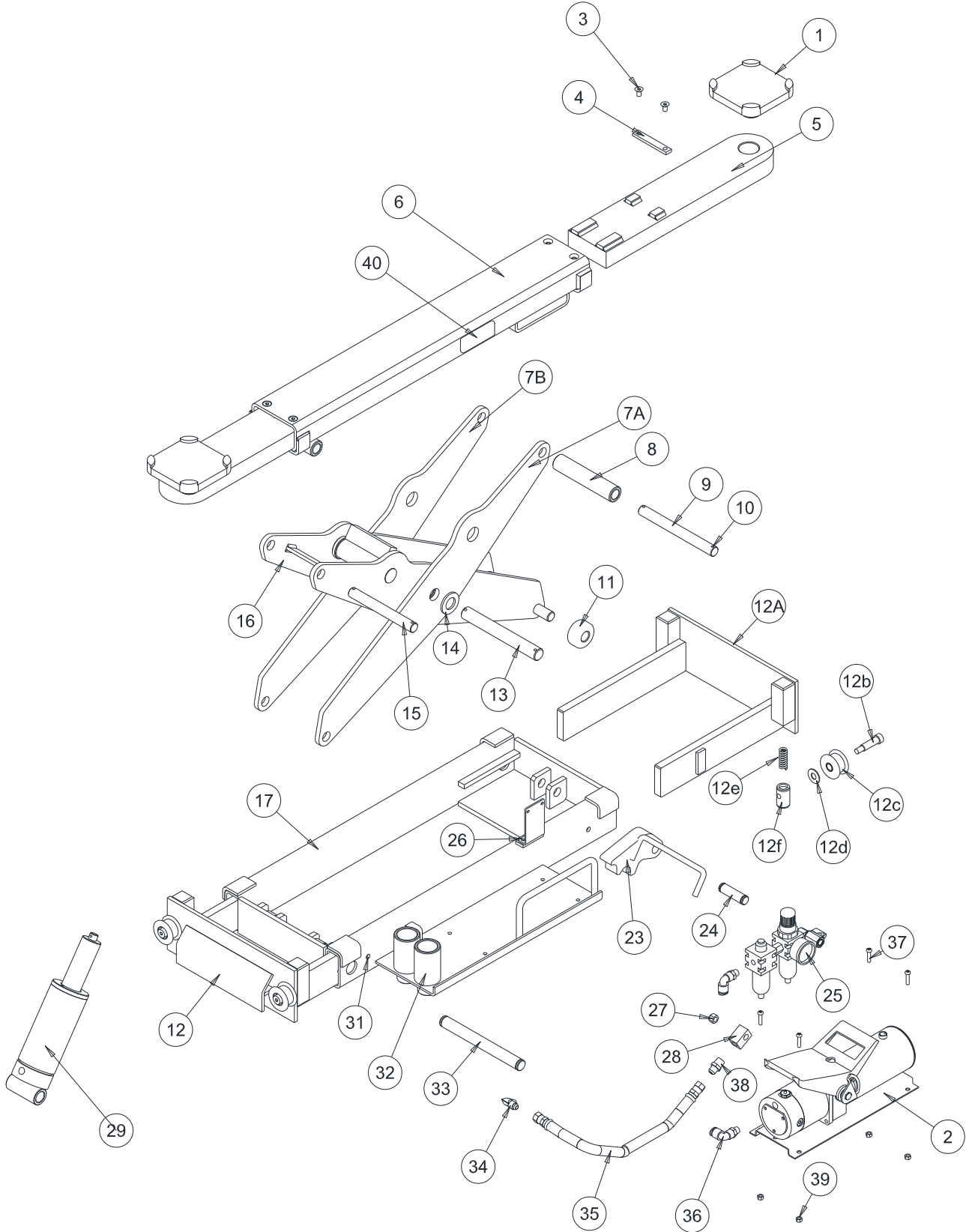

RJ9 Installation, Operation and Maintenance Manual

Item	Part Number	Qty/Jack	Description	
1	RJ9-04-00	2	Foot Pad	
2	PA133U113	1	Air/Oil Pump	
3	VS10-31-08	4	M8 x 12 Flat Head Screw	
4	RJ6-19	2	Stop Bar	
5	RJ6-02CH	2	Arm	
6	RJ7.5-01	1	Sleeve	
7A	RJ7.5-07F	1	Outer Scissor Plate, Front	
7B	RJ7.5-07R	1	Outer Scissor Plate, Rear	
8	RJ6-06-04	1	Upper Pin Roller	
9	RJ6-13	1	Upper Pin	
10	VS10-20-10	6	5mm Roll Pin	
10A	X10-099	4	20mm Washer	
11	RJ6-18	2	Roller	
12	RJ9A-15-00	2	Side Member Assembly	44018AR, 44018XAR
	RJ9S-15-00			44018, 44018E
12a	<i>RJ9A-15A</i>	2	Side Member Weld	44018AR, 44018XAR
	<i>RJ9S-15A</i>			44018, 44018E
12b	<i>RJ6-27CH</i>	4	16mm Dia. Shoulder Bolt	
12c	<i>RJ6-17CH</i>	4	Wheel	
12d	<i>RJ6-24CH</i>	4	Nylon Washer	
12e	<i>RJ6-26A</i>	4	Compression Spring	
12f	<i>RJ6-25CH</i>	4	Carrier	
13	RJ6-08	1	Main Pin	
14	RJ6-23	2	Spacer Washer	
15	RJ6-12	1	Upper Pin, Fixed End	
16	RJ7.5-06	1	Internal Scissor	
17	RJ7.5-11	1	Jack Body	
23	RJ7.5-16	1	Lock	
24	RJ7.5-20	1	Lock Pin	
24A	RJ7.5-35	2	21mm Snap Ring	
25	24101	1	FLR Assembly, Including Gage and Fittings	
26	RJ6-28	1	FLR Bracket	
27	X10-096	1	M10 Nylon Locknut	
28	351450	1	Hose Block	
28A	RJ6-37	1	4mm x 50mm Cotter Pin	
29	RJ6-09CHA	1	Cylinder, Flow-Restricted	
31	X10-077	4	M10 x 25 HHCS	
31A	RJ6-38	4	M10 Hex Nut	
32	RJ6-05	4	3" Stack Pad	
33	RJ6-14	1	Cylinder Pin	
33A	RJ6-40	2	15mm Snap Ring	
34	RJ6-22CH	1	Hydraulic Elbow	
35	RJ6-21CH	1	Hydraulic Hose	
36	RJ6-31	2	10mm Push Loc Elbow	
37	RJ6-41	4	M6 x 25 Allen Screw	
38	JSJ3-10-04	1	3/8 NPT x M14 37 Deg Flare Adapter	
39	B31061	4	M6 Nylon Locknut	
40	Z16777	1	Jack Capacity Decal	

IMPORTANT!

Replace all worn, damaged, or broken parts with parts approved by **Challenger Lifts Inc.**
or with parts meeting **Challenger Lifts Inc.** specifications.
Contact your local Challenger Lifts Parts Distributor for pricing and availability.
(Call Challenger Lifts Inc. (502) 625-0700 for the Parts Distributor in your area)